

APEX

COLOR TELEVISION SERVICE MANUAL

MODEL NO.: AT1302

CHASSIS NO.: CN-12C

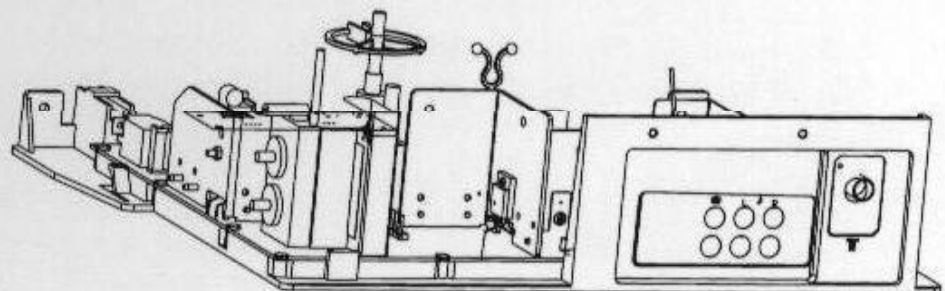

CONTENTS

SAFETY INSTRUCTIONS	1
SPECIFICATIONS	3
KEY ICs AND ASSEMBLIES	3
SIGNAL PROCESS AND SYSTEM BLOCK DIAGRAMS	4
IC DATA AND WAVEFORMS OF KEY POINTS	11
CIRCUIT ADJUSTMENTS	24
SET-UP ADJUSTMENTS	25
SERVICE MODE AND BUS DATA	28
TROUBLESHOOTING FLOW CHARTS	31
PARTS LIST	38
APPENDIX 1. CIRCUIT DIAGRAM	
2. PRINTED CIRCUIT BOARD DIAGRAMS	
3. FINAL ASSEMBLY DIAGRAM AND FINAL WIRING DIAGRAM	

SAFETY INSTRUCTIONS

WARNING: BEFORE SERVICING THIS CHASSIS, READ THE "X-RAY RADIATION PRECAUTION", "SAFETY PRECAUTION" AND "PRODUCT SAFETY NOTICE" INSTRUCTIONS BELOW.

X-RAY RADIATION PRECAUTION

1. The EHT must be checked every time the TV is serviced to ensure that the CRT does not emit X-ray radiation as result of excessive EHT voltage. The nominal EHT for this TV is 27.5KV at zero beam current (minimum brightness) operating at AC 120V. The maximum EHT voltage permissible in any operating circumstances must not exceed 30KV. When checking the EHT, use the High Voltage Check procedure in this manual using an accurate EHT voltmeter.
2. The only source of X-RAY in this TV is the CRT. To prevent X-ray radiation, the replacement CRT must be identical to the original fitted as specified in the parts list.
3. Some components used in this TV have safety related characteristics preventing the CRT from emitting X-ray radiation. For continued safety, replacement component should be made after referring the PRODUCT SAFETY NOTICE below.

SAFETY PRECAUTION

1. The TV has a nominal working EHT voltage of 27.5KV. Extreme caution should be exercised when working on the TV with the back removed.
 - 1) Do not attempt to service this TV if you are not conversant with the precautions and procedures for working on high voltage equipment.
 - 2) When handling or working on the CRT, always discharge the anode to the TV chassis before removing the anode cap in case of electric shock.
 - 3) The CRT, if broken, will violently expel glass fragments. Use shatterproof goggles and take extreme care while handling.
 - 4) Do not hold the CRT by the neck as this is a very dangerous practice.
2. It is essential that to maintain the safety of the customer all power cord forms be replaced exactly as supplied from factory.
3. Voltage exists between the hot and cold ground when the TV is in operation. Install a suitable isolating transformer of beyond rated overall power when servicing or connecting any test equipment for the sake of safety.
4. Replace blown fuses within the TV with the fuse specified in the parts list.
5. When replacing wires or components to terminals or tags, wind the leads around the terminal before soldering. When replacing safety components identified by the international hazard symbols in the circuit diagram and parts list, it must be the company-approved type and must be mounted as the original.
6. Keep wires away from high temperature components.

SAFETY INSTRUCTIONS (continued)

PRODUCT SAFETY NOTICE

Many electrical and mechanical components in this chassis have special safety-related characteristics. These characteristics are often passed unnoticed by a visual inspection and the X-ray radiation protection afforded by them cannot necessarily be obtained by using replacements rated at higher voltages or wattage, etc. Components which have these special safety characteristics in this manual and its supplements are identified by the international hazard symbols in the circuit diagram and parts list. Before replacing any of these components read the parts list in this manual carefully. Substitute replacement components which do not have the same safety characteristics as specified in the parts list may create X-ray radiation.

PRECAUTIONS

Power Sources—The TV set should be operated only from the type of power source indicated on the TV set or as indicated in the Service Manual. If you are not sure of the type of power supply in your home, consult your sales person or your local power company. For TV sets designed to operate from battery power, or other sources, refer to the operating instructions.

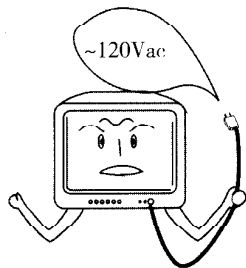

Grounding or Polarization—Do not defeat the safety purpose of the polarized or grounding-type plug. A polarized plug has two blades with one wider than the other. A grounding-type plug has two blades and a third grounding prong. The wide blade or the third prong is provided for your safety. If the provided plug does not fit into your outlet, consult an electrician for replacement of the obsolete outlet.



Wide blade
Lame large
Cuchilla ancha

Alternate Warnings—A three wire grounding type plug—a plug having a third (grounding) pin. This plug will only fit into grounding type power outlet.

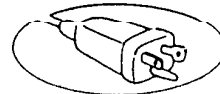

Water and Moisture Warnings—Do not use the TV set near water—for example, near a bath tub, wash bowl, kitchen sink, or laundry tub; in a wet basement; or near a swimming pool; and the like. The TV set shall not be exposed to dripping or splashing and no objects filled with liquids, such as vases, shall be placed on the TV set.

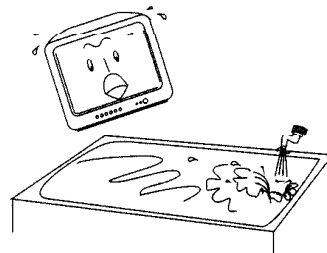

Ventilation—Slots and openings in the cabinet are provided for ventilation and to ensure reliable operation of the TV set and to protect it from overheating, and these openings must not be blocked or covered. The openings should never be blocked by placing the TV set on a bed, sofa, rug, or other similar surface. This TV set should not be placed in a built-in installation such as a bookcase or rack unless proper ventilation is provided or the manufacturer's instructions have been adhered to.

SPECIFICATIONS

Television system:	NTSC-M
Channel coverage:	VHF 2~13 UHF 14~69 CABLE TV: MID BAND (A-8~A-1, A~I) SUPER BAND (J~W) HYPER BAND (AA~ZZ, AAA, BBB) ULTRA BAND (65~94, 100~125)
Channels preset:	181
Antenna input:	75Ω (unbalanced)
Picture tube:	Effective screen dimensions: 280mm×210mm (11.02×8.27 in.) (Approx.)
Audio output:	1W×2 (THD ≤ 7%)
Power source:	~120Vac 60Hz
Weight:	11.5kg (25.3 lbs) (Approx.)
Dimensions(W/H/D):	373×356×370mm (14.69×14.02×14.57 in.) (Approx.)
Packing dimensions(W/H/D):	450×425×425mm (17.72×16.73×16.73 in.) (Approx.)
Rated power consumption:	~70W

KEY ICS AND ASSEMBLIES

Table 1 Key ICs and Assemblies

Serial No.	Position No.	Model No.	Function Description
1	N101	LA76814	Small signal processor
2	N301	LA7840	Vertical output circuit
3	N503	L7805	Tri terminal regulator
4	N181	LA4225	Sound power amplifier
5	D701	LC86F3248A	Microcontroller
6	D702	ST24C04	EEPROM
7	U101	TDQ-6F2M	Tuner

SIGNAL PROCESS AND SYSTEM BLOCK DIAGRAMS

CN-12C chassis comprises a LA76814 (N101) small signal processor, LA4225 (N181) sound power amplifier, LA7840 (N301) vertical output circuit, TV/Video switch circuit, LC86F3248A (D701) microcontroller, AT24C08 (D702) EEPROM and discrete components including a horizontal output circuit, video amplifier and power circuit as shown in Fig.1. The following give descriptions of signal flow process of AT1302 according to different channels in the LA76814 small signal processor.

1. Common Channel

The common channel includes a tuner, IF filter circuit, PIF amplifying circuit and audio/video separating circuit.

In accordance with Fig.1 and the circuit diagram, the RF TV signal received by the antenna is tuned, high-frequency amplified and converted in U101 tuner to develop a PIF signal (38MHz) and SIF signal (33.5MHz). Then the two signals are sent to Z101 surface acoustic wave filter for IF filtering after IF amplified by V101 pre-PIF amplifier and compensating insertion loss of the SAW filter and to the PIF amplifier through N101's Pin5 and Pin6.

In N101, the IF signal is separated out a video signal as well as a second SIF signal (4.5MHz) after multipolar amplified by the IF amplifier through PLL video detecting (see Block Diagram of LA76814). After externally connecting Pin48 and Pin49 of N101 to L201 tuning loop of VCO phase-locked loop, and Pin47, Pin50 to the low-pass filter of phase-locked loop APC formed of C239, C242, C244, R219 and R220, video signals are separated from the two generated signals by the inner trap and output in two ways. One set is output from N101's Pin46 to Pin44 after divided by R221 and R223 and coupled by C248. Another set is output from N101's Pin52 to the audio channel. So TV signal processing in common channel has been completed.

An AGC circuit is also set in the common channel to ensure the TV normal operation even with too strong or too weak signal reception. Externally connect N101's Pin3 to C204 filter capacitor of IFAGC and Pin4 to the output terminal of RFAGC. RFAGC control voltage is sent to the AGC terminal of U101 tuner to control gain of HF amplifier.

A set of carrier frequency signal (38MHz) is also output from VCO of the PLL video detecting circuit to the AFT circuit by which AFT voltage is generated and output from N101's Pin10 to Pin14 of D701 microcontroller, used for auto program and fine tune of tuner.

2. Sound IF Circuit (See System Block Diagram of LA76814)

The second SIF FM signal output from N101's Pin52 is filtered out part of video signals by the T high pass filter comprising C240, C238 and L287, then buffer amplified by the V231 emitter follower, coupled by C235, finally sent into the audio channel in N101 through N101's Pin54.

The Second SIF signal in N101 is further separated out through the band pass filtering, then audio signal is generated from the FM signals after through amplitude-limited amplifying, PLL discrimination and output in two ways after low-pass filtered by the deemphasis circuit: In one way the signal is output from N101's Pin2; in another way, the signal is switched over with external audio signal input from N101's Pin51 through volume control and audio amplifying, then output from N101's Pin1 (suitable for AT1302 due to no volume control in the sound power amplifier). Externally connect N101's Pin53 to the APC low pass filter comprising C234, C236 and R217 of the PLL discriminator, and Pin2 to the C202 deemphasis capacitor. Audio signal from N101's Pin2 can be output from the A-OUT (audio output) ter-

SIGNAL PROCESS AND SYSTEM BLOCK DIAGRAMS (continued)

minals after amplified by V802 and V803 and coupled by C803.

The TV audio signal output from N101's Pin1 is coupled by C161 to N181 sound power amplifier.

3. TV/Video Switch Circuit

The TV/Video switch circuit mainly includes the switch circuit in N101. TV video signal from N101's Pin46 is sent to N101's Pin44 and video signal from the front-set or rear-set AV terminals sent to N101's Pin42 after coupled by C802. Two sets of video signals are sent into the luminance channel, chroma channel and sync separator respectively through switchover of the inner switch circuit. In addition, the switched video signal is output from N101's Pin40 to the V-OUT (video output) terminals through V801 emitter follower or D701's Pin19.

The audio signal input from the front-set or rear-set AV terminals is sent to N101's Pin51 after coupled by C801 and C808 and output from N101's Pin1 to the sound power amplifier after switched over with the TV audio signal from the sound demodulator in N101 and volume-controlled.

4. Sound Power Amplifier

The sound power amplifier is formed of a LA4225 (N181). The audio signal from N101's Pin1 is input to N181's Pin1 after coupled by C161, C183 and divided by R161, R185 and is output from N181's Pin4 through OTL power amplifying, driving the speakers to output sound.

V183 and V185 are formed into a mute control circuit. When Pin2 of the D701 microcontroller outputs high level, V183 and V185 saturate and conduct. AC short-circuit audio signal input to N181's Pin1, thus mute control completed.

5. Video Signal Processor

The video signal processor incorporates a luminance channel, chroma channel and video amplifier. The luminance channel, all in LA76814, mainly includes a clamping circuit, video switch circuit, chroma trap, luminance delay, peaking coring circuit, black level stretcher, contrast control circuit and luminance control circuit. The chroma channel, all in LA76814, mainly includes an ACC circuit, killer identification circuit, sub-carrier restorer, NTSC color difference demodulator, color difference switch, 1H baseband delay line, color difference matrix, primary color matrix and RGB circuit, all of which are controlled by the I²C bus.

Two sets of video signals input from N101's Pin44 and Pin42 are output in two ways after through clamp DC level restoration and switchover of the video switch circuit: One set of signal is filtered out a chroma signal by the color band pass filter and sent into the chroma channel; another set is filtered out a luminance signal by the color trap and sent into the luminance channel and sync separator.

In luminance channel, the luminance signal is sent to the primary matrix circuit through delay and definition control. Externally connect Pin45 of N101 to the filter formed of C246 and R225 in the black level detector.

Through ACC amplifying and NTSC color difference demodulation, the chroma signal in the chroma channel is restored to two color difference signals: R-Y and B-Y, which are sent to the color difference matrix to restore to a G-Y color difference signal through 1H baseband delay. Then the three kinds of color difference signals are sent into the primary color matrix together with the luminance signal to restore to three primary color signals: R, G, B. Externally connect N101's Pin 35 to the C260 filter capacitor in the auto killer circuit, Pin36 to the filter incorporating C254, C256 and R235 in the APC sub-

SIGNAL PROCESS AND SYSTEM BLOCK DIAGRAMS (continued)

carrier restorer, Pin38 to the G201 3.58MHz crystal oscillator in the sub-carrier restorer, Pin39 to the C274 filter capacitor in the ACC circuit respectively. When N101's Pin17 outputs high level, three primary colors signals output from the short matrix circuit mix with the character primary colors input from Pin14, Pin15 and Pin16 of N101, which then are output from Pin19, Pin20 and Pin21 of N101 through white balance calibration to the video amplifier to drive the CRT to display pictures.

The video amplifier incorporates discrete components, including V901, V902 and V903 video amplifying transistors, a DC bias regulator incorporating V905, D904, D905, R909, R910, R911 and R912 and bleeding power-off spot killer incorporating V904, D906, C906, C907 and R913.

6. Scan Circuit

The scan circuit includes a scan previous stage circuit, vertical output circuit and horizontal output circuit. The scan previous stage located in LA76814, a dividing scan circuit, comprises a horizontal oscillator, horizontal divider, AFC1, AFC2, phase shifter, line drive, field divider, sawtooth former, linefield sync.

The horizontal oscillator in N101 is a 4MHz (256f_H) voltage-controlled oscillator whose free oscillating frequency is controlled by the R245 resistor externally connected to Pin29 by means of the bus data adjustment. To reach horizontal sync, the AFC1 phase discriminator controls the voltage-controlled oscillator. After the AFC1 comparing frequency and phase of the horizontal frequency pulse output from the horizontal divider to those of the horizontal sync pulse from the sync separator, two error voltages directly proportional to pulse phase difference are generated to control sync of the voltage-controlled oscillator. Externally connect N101's Pin26 to AFC1's low pass filter comprising C228, C230 and R211.

4MHz oscillating pulse strictly locked by the AFC1 outputs a horizontal frequency pulse signal to the horizontal phase shifter controlled by the AFC2 phase discriminator after divided by the horizontal divider. After the AFC2 comparing the horizontal frequency signal (used as a reference signal) output from the horizontal divider to horizontal flyback pulse input from Pin28, an error voltage directly proportional to the phase difference is generated to control phase shift capacity of the phase shifter and perform calibration of horizontal center.

After properly amplified through calibration of the horizontal center, the horizontal frequency pulse is output from N101's Pin27 to V431 line drive for pulse amplifying and shaping. After coupled by T401 line drive transformer, amplified and controlled by the horizontal output circuit, horizontal sawtooth current is generated in the horizontal deflection yoke, finally a scan field changing vertically is formed to control the electronic beams in CRT and complete horizontal scan. In the horizontal output stage, V432 is a horizontal output transistor including a damping diode, C435, C436 and C437 are flyback capacitors, T432 is a flyback transformer, C442 is a S correction capacitor, L441 is a horizontal linearity inductor coil, L442 is a horizontal amplitude inductor coil and H-DY is a horizontal deflection yoke.

During normal operation, the horizontal output circuit also develops horizontal flyback pulse with amplitude of nearly 1KV, which is voltage-dropped by T432 flyback transformer in two ways. In one way, T432's Pin10 outputs filament voltage. Later the flyback pulse is processed into high voltage, focus voltage, screen voltage through step-up, high-voltage pulse rectifying and filtering. All of the four voltages are supplied to the CRT. In another way, the horizontal flyback pulse output from Pin1 of T432 is process into +190V DC voltage for the video amplifier after pulse-rectified by VD555A and filtered by C555A. T432's Pin3 outputs the dropped horizontal flyback pulse to N101's Pin28 (one way) and

SIGNAL PROCESS AND SYSTEM BLOCK DIAGRAMS (continued)

D701's Pin21 (another way). Externally connect T432's Pin7 to C422, R424, R423, VD405, VD403 and C444 in ABL circuit.

In N101, horizontal frequency pulse signal output from the horizontal divider is also sent into the vertical divider to develop a vertical frequency pulse signal through vertical division. To reach vertical sync, the vertical divider is also controlled by vertical sync pulse output from the sync separator. The vertical frequency pulse signal is sent to the sawtooth former for sawtooth transformation to develop vertical sawtooth voltage which is output from N101's Pin23 to the vertical output stage circuit. Externally connect N101's Pin24 to C220 and C222 filter capacitors of the ALC circuit.

The horizontal output stage consists of a LA7840 (N301). Vertical sawtooth voltage from N101's Pin23 is input from N301's Pin5 to Pin2 through power amplification, and then sent to the vertical deflection yoke to develop vertical frequency sawtooth current. By this means, a scan magnetic field changing horizontally is formed to control electronic beams in the CRT and complete vertical scan. N301's Pin4 functions as an in-phase input terminal for the vertical output stage. This TV is equipped with a DC bias circuit incorporating R301, R323 and C321 to regulate the operation point. N301's Pin6 functions as a +25V supply voltage input terminal, Pin3 as a +50V pump supply voltage input terminal, and Pin7 as a vertical flyback pulse output terminal. C301, C304, C306, R304, R305, R307, R313 and R314 are formed into a vertical DC/AC negative feedback circuit, of which DC negative feedback is used for regulating the operation point and AC negative feedback for improving vertical linearity.

Refer to Fig. 2 about the block diagram for CN-12C chassis supply voltage system and Fig. 3 about the block diagram for the remote control structure.

SIGNAL PROCESS AND SYSTEM BLOCK DIAGRAMS (continued)

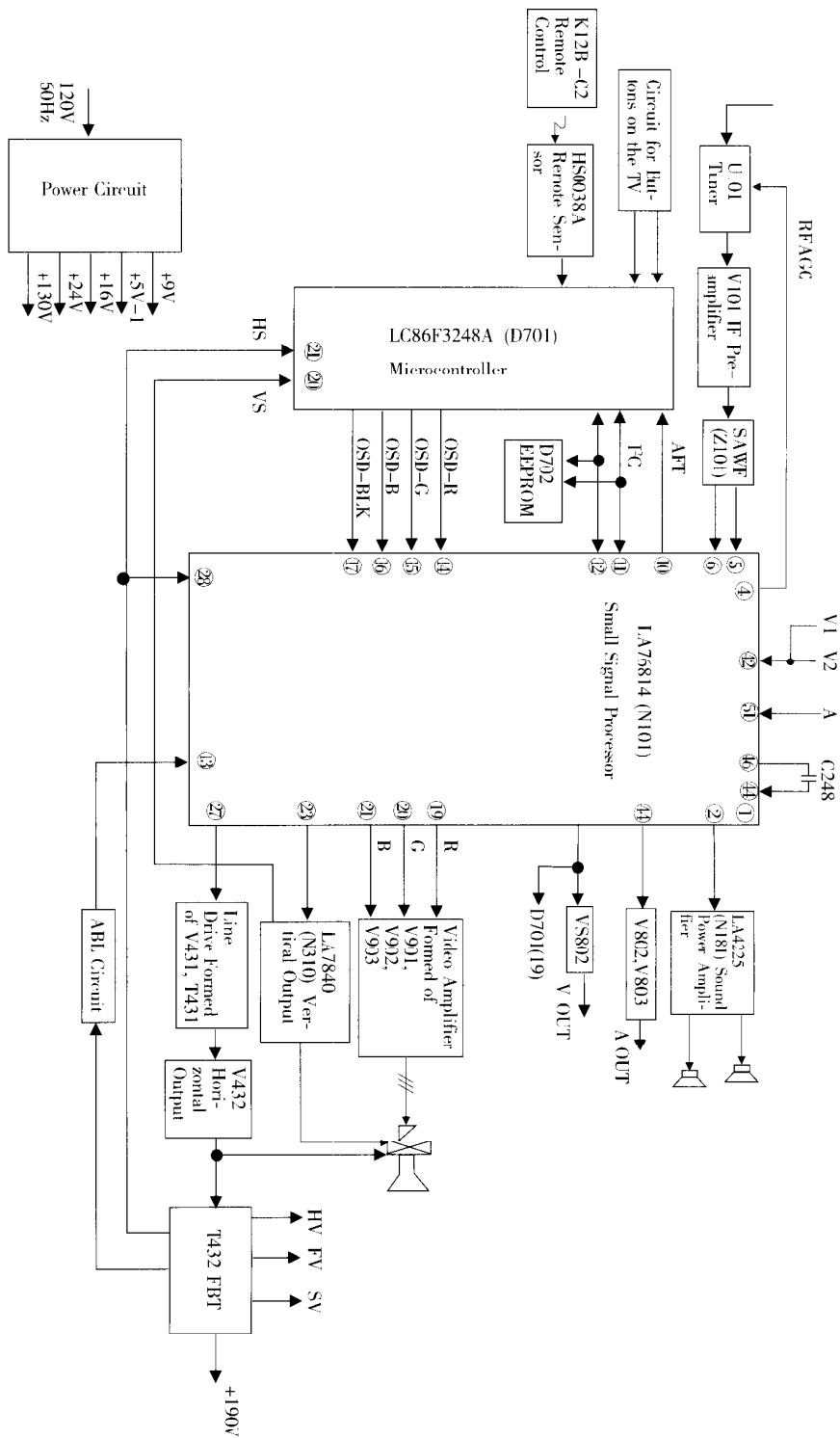

Fig. 1 Basic Structure Block Diagram for CN-12C Chassis

SIGNAL PROCESS AND SYSTEM BLOCK DIAGRAMS (continued)

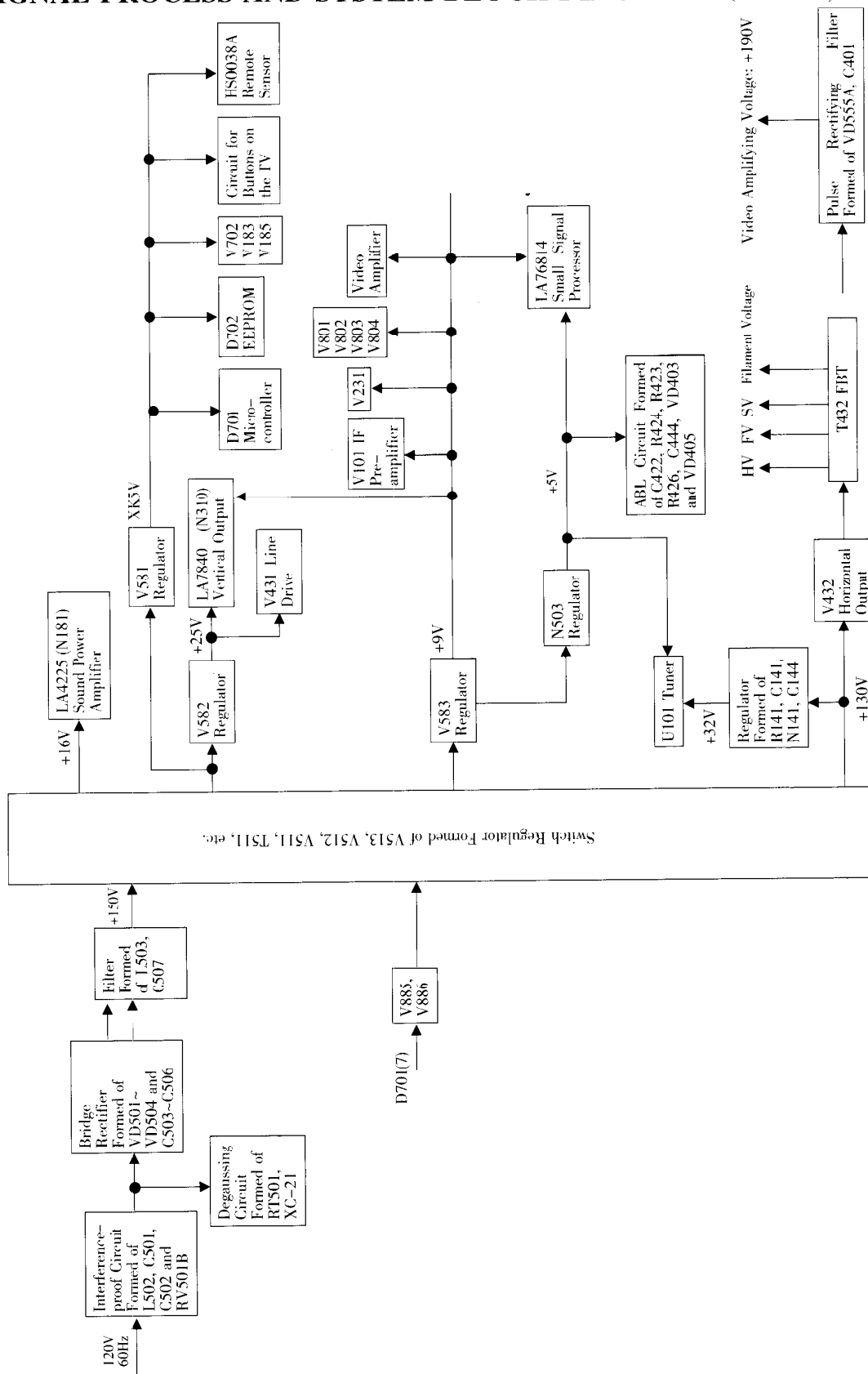

Fig. 2 Block Diagram for CN-12C Supply Voltage System

SIGNAL PROCESS AND SYSTEM BLOCK DIAGRAMS (continued)

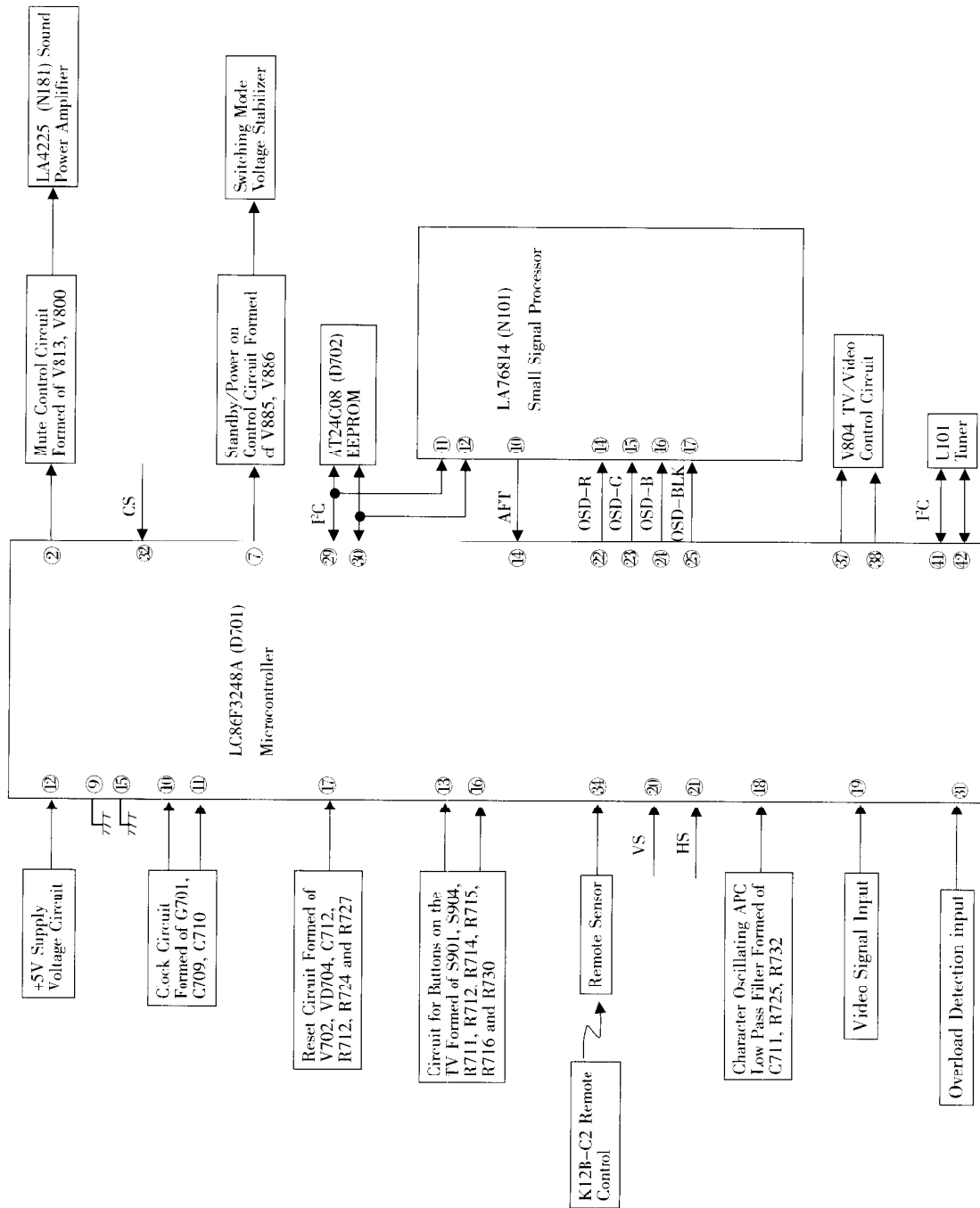

Fig. 3 Block Diagram for CN-12C Remote Control Structure

IC DATA AND WAVEFORMS OF KEY POINTS

LA76814 Small Signal Processing IC

1. Introduction of LA76814 IC

LA76814 is a NTSC-M only system color TV specific monolithic IC developed by SANYO Co., which is controlled by Inter IC Bus. LA76814 includes a IF processing circuit, a luminance and chroma signal processing circuit, horizontal/frame scanning small signal processing circuit etc. It has following features.

*Number of external component adjustments reduced by the use of an IC bus and by reducing the number of on-board rheostats.

An IC bus is used for controlling this IC, and this allows the number of adjustment that require trimmers on the printed circuit board to be reduced.

*Number of adjustments reduced by the adoption of adjustment-free technology. The VCO coil adjustment and the AFT coil adjustment are now handled by adjustment-free technology.

*Number of external components reduced by the adoption of circuit technologies.

-S-TRAP, S-BPF

The sound trap and sound bandpass filter circuits, which were previously implemented using external components, are now provided on chip.

-Horizontal oscillator element

The horizontal oscillator element, which was previously an external component is now provided on chip.

-Single crystal operation provided by DDS technology

The functions of the two or three crystal oscillator elements previously required for color demodulation can now be handled by a single crystal oscillator element due to the adoption of DDS technology.

IC DATA AND WAVEFORMS OF KEY POINTS (continued)

LA4425 (N181)

W Power Amplifier with Very Few External Parts for Car Radio and Car Stereo

1. Features

- The world's first power amplifier with very few external parts.
 - The smallest package in the industry
 - [SIP-5H(TO-126 type)]
 - Only two external parts
 - [Only I/O coupling capacitors]
- Almost no evaluation, adjustment and check as a power IC required
 - [Simplified control]
- Wide operation supply range
 - 5 to 16 V.
- On-chip protection:
 - Overvoltage protection
 - Thermal Protection
 - Output D.C. short protection
- On-chip pop noise reducing circuit

2. Sample Application Circuit

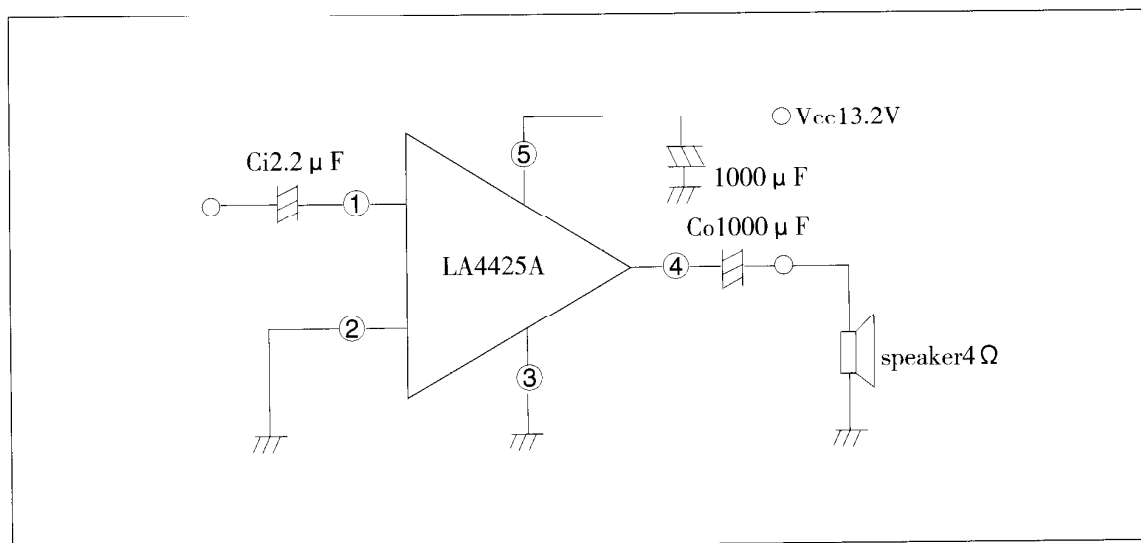

Fig. 5

3. Refer to Table 3 about Functions and Service Data of LA4425's Pins.

IC DATA AND WAVEFORMS OF KEY POINTS (continued)

LC86F3248A (D701)

8-Bit Single Chip Microcontroller

1. Overview

The LC863264/56/48/40A are 8-bit single chip microcontrollers with the following on-chip functional blocks:

- CPU: Operable at a minimum bus cycle time of 0.42 μ s
 - On-chip ROM capacity
 - Program ROM: 64K/56K/48K/40K bytes
 - CGROM: 16K bytes
 - On-chip RAM capacity: 640 bytes
 - OSD RAM: 352 \times 9 bits
 - Closed-Caption TV controller and the on-screen display controller
 - Closed-Caption data slicer
 - Four channels \times 8-bit AD Converter
 - Three channels \times 7-bit PWM
 - Two 16-bit timer/counters, 14-bit base timer
 - 8-bit synchronous serial interface circuit
 - IIC-bus compliant serial interface circuit (Multi-master type)
 - ROM correction function
 - 16-source 10-vectored interrupt system
 - Integrated system clock generator and display clock generator
 - Only one X'tal oscillator (32.768kHz) for PLL reference is used for both generators
 - TV control and the Closed Caption function
- All of the above functions are fabricated on a single chip.

2. Terminal Assignment Layout

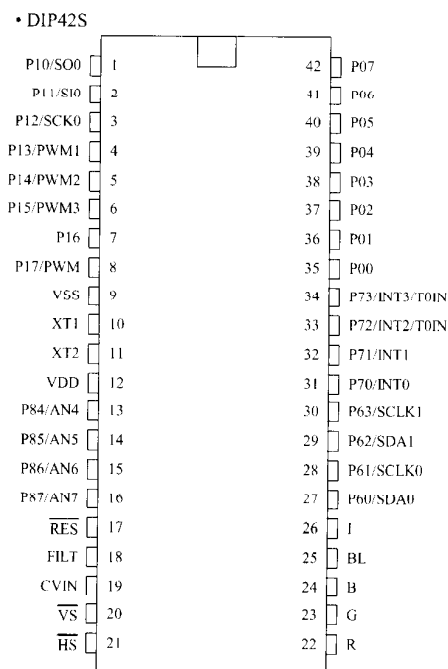

Fig. 6

3. Refer to Table 4 about Functions and Service Data of D701's Pins.

IC DATA AND WAVEFORMS OF KEY POINTS (continued)

ST24C04 (D702) EEPROM

1. Features

- Data EEPROM internally organized as 512 bytes and 32 pages×16 bytes
- Page protection mode, flexible page-by-page hardware write protection
- Additional protection EEPROM of 32 bits, 1 bit per data page
- Protection setting for each data page by writing its protection bit
- Protection management without switching WP pin
- Low power CMOS
- V_{CC}=2.7 to 5.5V operation
- Two wire serial interface bus, I²C-Bus compatible
- Filtered inputs for noise suppression with Schmitt trigger
- Clock frequency up to 400 kHz
- High programming flexibility
- Internal programming voltage
- Self timed programming cycle including erase
- Byte-write and page-write programming, between 1 and 16 bytes
- Typical programming time 6 ms(<10ms) for up to 16 bytes
- High reliability
- Endurance 10⁶ cycles¹⁾
- Data retention 40 years¹⁾
- ESD protection 4000 V on all pins
- 8 pin DIP/DSO packages
- Available for extended temperature ranges
- Industrial: -40°C to +85°C
- Automotive: -40°C to +125°C

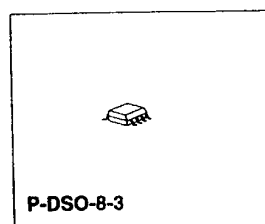
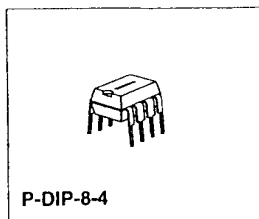

2. Pin Configuration

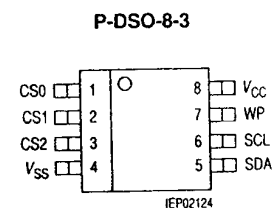
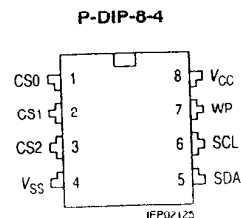

3. Block Diagram

4. Refer to Table 5 about Functions and Service Data of ST24C04's Pins.

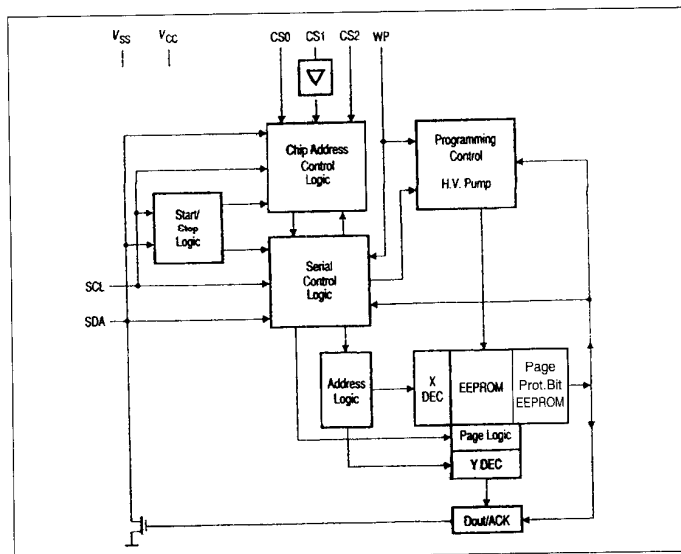

Fig. 7

IC DATA AND WAVEFORMS OF KEY POINTS (continued)

LA7840 (N301)

Vertical Deflection Output Circuit

1. Features

- Low power dissipation due to built-in pump-up circuit
- Vertical output circuit
- Thermal protection circuit built in
- Excellent crossover characteristics
- DC coupling possible

2. Block Diagram

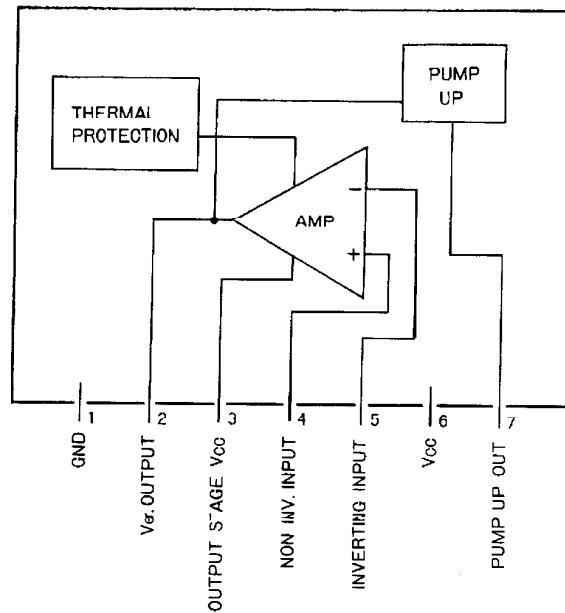

Fig. 8

3. Refer to Table 6 about Functions and Service Data of LA7840's Pins.

IC DATA AND WAVEFORMS OF KEY POINTS (continued)

Table 2 Functions and Service Data of LA76814 (N101)'s Pins

Pin No.	Function Description	GDM8145 Multimeter		
		Voltage of Pin (V)	Ground Resistance (K Ω)	
			Measure with red probe while grounding black probe.	Measure with black probe while grounding red probe.
1	Audio output terminal	2.25	6.73	6.75
2	FM demodulation audio output	2.27	6.57	6.57
3	IF AGC filter	1.91	7.05	6.60
4	RF AGC output	3.72	∞	6.43
5	IF signal input	2.86	6.76	6.49
6	IF signal input	2.86	6.75	6.46
7	IF circuit ground	0	0	0
8	Supply voltage for IF circuit	5.0	0.41	0.41
9	DC loop filter for FM demodulator	2.04	7.42	6.60
10	AFT output	2.31	7.08	5.48
11	Data line	4.87/4.90	11.94	5.55
12	Clock line	4.78/4.84	11.95	5.75
13	ABL control input terminal	3.87	5.38	5.16
14	R character input	1.17	7.38	6.52
15	G character input	1.19	7.38	6.52
16	B character input	1.19	7.38	6.52
17	Fast blanking signal input	0.01	7.26	3.25
18	Supply voltage for RGB circuit	8.05	0.47	0.47
19	R signal output	2.62	5.54	6.32
20	G signal output	2.54	5.56	6.33
21	B signal output	2.56	5.56	6.33
22	B.AKB control voltage input terminal	0.05	7.37	6.42
23	Field sawtooth output	2.62	7.29	2.3
24	Vertical ALC control filter	2.61	7.07	6.50
25	Supply voltage for horizontal scanner/bus interface circuit	5.13	0.54	0.54
26	Horizontal AFC filter	2.68	7.23	6.55
27	Horizontal frequency pulse output	0.73	1.40	1.40
28	Horizontal flyback pulse input	1.19	6.90	6.46
29	Resistance resulted from external reference current	1.71	4.68	4.67
30	Not connected	0	∞	∞

(Continued)

IC DATA AND WAVEFORMS OF KEY POINTS (continued)

31	Not connected	0	∞	∞
32	OSD gain control	4.97	1.4	1.40
33	Deflection circuit ground	0	0	0
34	X-ray detector filter	0	6.62	6.13
35	Killer filter	0.36	7.06	6.61
36	APC filter of sub-carrier restorer	3.41	6.96	6.50
37	3.58 MHz sub-carrier signal output terminal	0.67	7.33	6.58
38	External 3.58MHz crystal oscillator	2.77	7.15	6.60
39	ACC circuit filter	2.33	7.19	6.48
40	Selectable video signal output	2.51	2.01	2.0
41	Video/chroma/deflection circuit ground	0	0	0
42	External video signal input/S-Video luminance signal input	2.50	7.20	6.60
43	Supply voltage for video/chroma/deflection circuit	4.95	0.42	0.42
44	Internal video signal input/S-Video chroma signal input	2.81	7.23	6.50
45	Black level detecting filter of black level stretcher	3.13	6.88	6.48
46	Video output terminal	3.01	1.63	1.63
47	PLL APC filter of video detector	3.43	7.26	6.55
48	PLL VCO coil of video detector	4.27	0.94	0.94
49	PLL VCO coil of video detector	4.27	0.94	0.94
50	PLL APC filter 2 of video detector	2.17	7.11	6.31
51	External audio signal input	2.19	7.28	6.66
52	Second SIF signal output	2.19	7.29	6.34
53	Second APC filter	2.40	7.14	6.46
54	Second SIF signal input	3.15	7.35	6.60

IC DATA AND WAVEFORMS OF KEY POINTS (continued)

Table 3 Functions and Service Data of LA4225 (N181)'s Pins

Pin No.	Function Description	GDM8145 Multimeter		
		Voltage of Pin (V)	Ground Resistance (KΩ)	
			Measure with red probe while grounding probe.	Measure with black probe while grounding red probe.
1	Audio signal input terminal	1.35	7.19	6.16
2	Ground	0	0	0
3	Ground	0	0	0
4	Audio signal output terminal	7.40	0.91	0.91
5	Supply voltage	16.10	10.43	4.16

Table 4 Functions and Service Data of LC86F3248A (D701)'s Pins

Pin No.	Function Description	GDM8145 Multimeter		
		Voltage of Pin (V)	Ground Resistance (KΩ)	
			Measure with red probe while grounding probe.	Measure with black probe while grounding red probe.
1	Bass control output	1.15	13.47	5.41
2	Mute control output terminal (effective with high level)	1.10	7.76	5.38
3	Not connected	0	13.47	5.41
4	SECAM identification (ground)	0	13.47	5.47
5	Volume control output	0	13.47	5.41
6	Not connected	0	13.45	5.51
7	Standby/Power-on control	0	10.96	5.50
8	Not connected	5.22	13.46	5.49
9	Ground	0	0	0
10	Clock oscillation signal input terminal	1.94	13.41	6.08
11	Clock oscillation signal output terminal	2.74	13.20	6.06
12	Supply voltage terminal	5.22	7.26	4.15
13	Button-control voltage input terminal	0	8.76	5.16
14	AFT voltage input terminal	3.35	7.40	5.50
15	Ground	0	0	0
16	Button-control voltage input terminal	0	8.30	5.16
17	Reset terminal	5.19	4.71	4.54
18	Filter	2.91	11.26	5.77
19	Video signal input terminal	2.78	13.22	6.01
20	Vertical flyback pulse input terminal	4.90	17.24	5.34

(Continued)

IC DATA AND WAVEFORMS OF KEY POINTS (continued)

21	Horizontal flyback pulse input terminal	4.49	17.22	5.38
22	R character output terminal	0	3.94	3.89
23	G character output terminal	0	3.95	3.89
24	B character output terminal	0	3.95	3.30
25	Fast blanking signal output terminal	0	6.55	5.06
26	Not connected	0	13.20	5.95
27	Not connected	0	13.20	5.92
28	Not connected	0	13.23	5.69
29	Data line	4.75/4.82	11.90	5.45
30	Clock line	4.75/4.86	11.92	5.60
31	Input terminal of overload detector	4.81	5.37	5.82
32	Selectable production mode input terminal (effective with low level)	5.22	11.83	5.27
33	Auto white balance signal output terminal	0.6	13.45	5.49
34	Remote signal input terminal	8.20	13.34	5.40
35	SIF switchover output terminal (Not connected)	0.58	13.46	5.48
36	Not connected	0	13.46	5.48
37	TV/Video control output terminal	5.11/0	9.69	5.20
38	TV/Video control output terminal	0	13.48	5.45
39	Not connected	0	13.47	5.37
40	Not connected	0	13.46	5.43
41	Clock line 1	4.86	9.02	4.99
42	Data line 1	4.88	8.87	5.09

Table 5 Functions and Service Data of ST24C04 (D702)'s Pins

Pin No.	Function Description	GDM8145 Multimeter		
		Voltage of Pin (V)	Ground Resistance (K Ω)	
			Measure with red probe while grounding probe.	Measure with black probe while grounding red probe.
1	Address terminal 0	0	0	0
2	Address terminal 1	0	0	0
3	Address terminal 2	0	0	0
4	Ground	0	0	0
5	Data line	4.87/4.92	12.31	5.41
6	Clock line	4.72/4.86	12.31	5.76
7	Write in/read out control terminal	0	0	0
8	Supply voltage	5	7.27	4.16

IC DATA AND WAVEFORMS OF KEY POINTS (continued)

Table 6 Functions and Service Data of LA7840 (N301)'s Pins

Pin No.	Function Description	GDM8145 Multimeter		
		Voltage of Pin (V)	Ground Resistance (KΩ)	
			Measure with red probe while grounding probe.	Measure with black probe while grounding red probe.
1	Ground	0	0	0
2	Vertical output terminal	9.73	0.58	0.58
3	Pump supply voltage input	24.88	∞	∞
4	In-phase input terminal	2.22	1.30	1.30
5	Inverting input terminal	2.22	4.58	4.55
6	Supply voltage	24.13	1.55	1.55
7	Pump supply voltage output/vertical flyback pulse output	2.61	7.09	5.93

Table 7 Each Electrode Voltage of Key Triodes

Position No. Electrode	V511	V512	V513	V553	V581	V582	V583	V702	V703	V704	V183	V185	V101	V231
B(V)	4.11	-0.50	-0.27	6.83	5.87	24.87	9.88	4.56	-0.02	0.15	0.64	0.64	1.72	4.50
C(V)	-0.50	-0.27	125.6	35.83	24.18	24.18	11.77	5.19	4.49	4.90	0	0	9.28	9.28
E(V)	4.54	0	0	6.33	5.24	24.14	9.29	5.24	0	0	0	0	0.95	3.83

Position No. Electrode	V801	V802	V803	V804	V431	V432	V901	V902	V903	V904	V905	N503
B(V)	1.49	2.27	0.01	0.70	0.17	1.98	2.61	2.53	2.54	0	0.85	(1)9.29
C(V)	0	9.28	9.28	0	17.50	100.45	107.4	111.50	111.58	4.59	0	(2)4.99
E(V)	2.20	1.62	1.62	0	0	2.02	2.29	2.22	2.23	0.18	1.53	(3)0

IC DATA AND WAVEFORMS OF KEY POINTS (continued)

Waveforms of Key Points

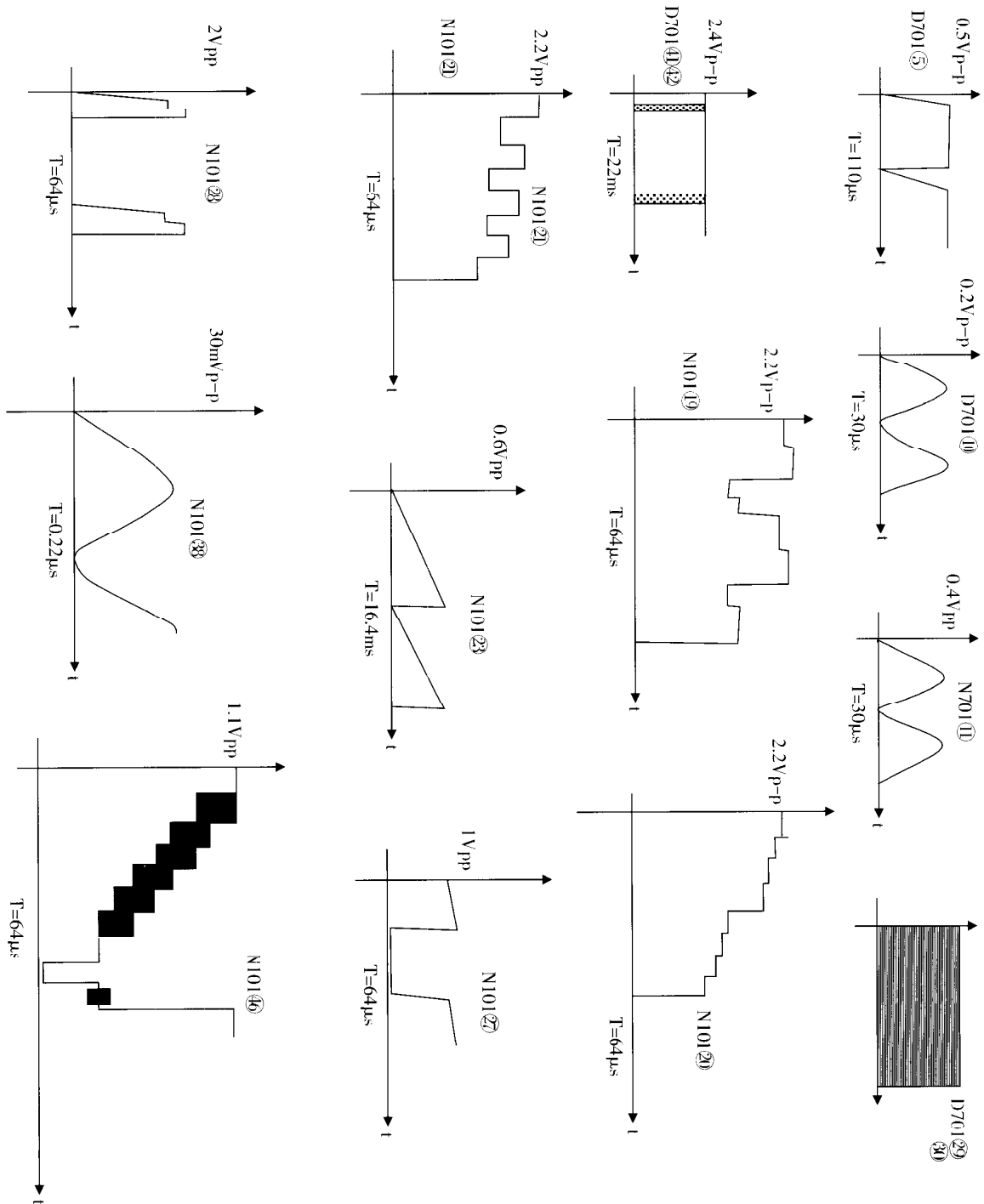

IC DATA AND WAVEFORMS OF KEY POINTS (continued)

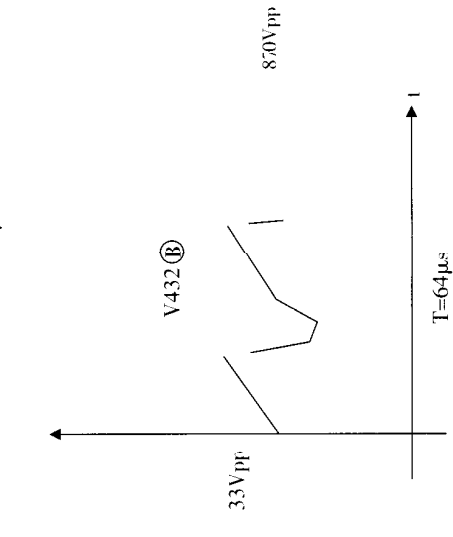
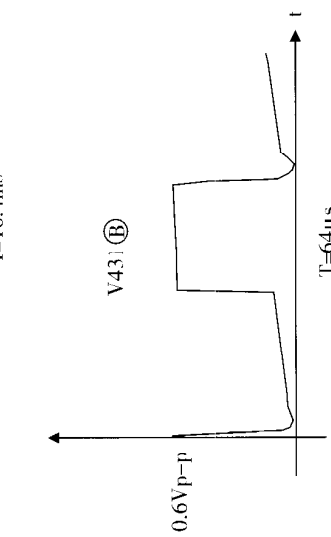
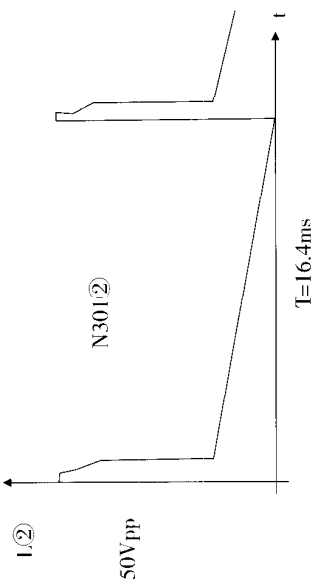
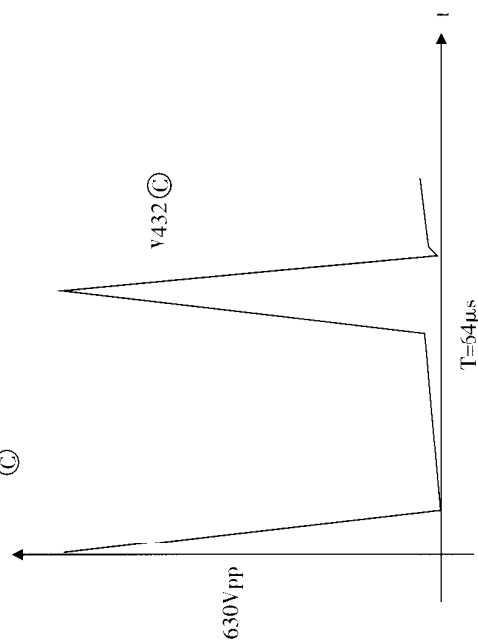
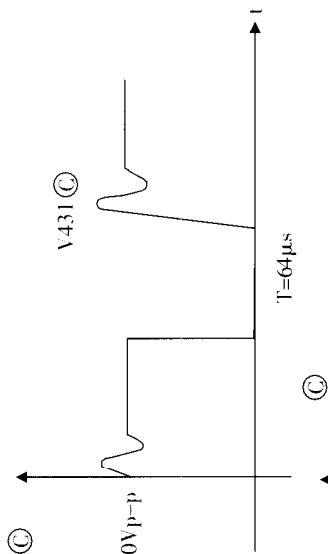
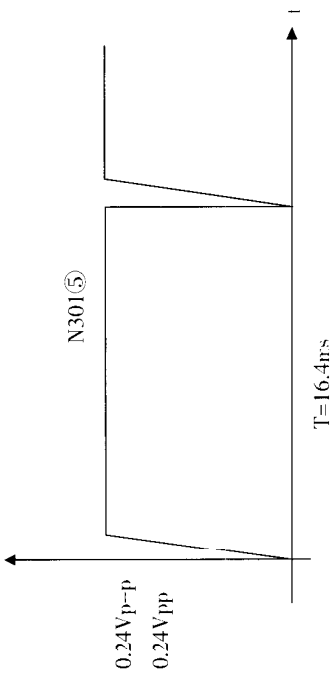

CIRCUIT ADJUSTMENTS

1. General Description

All adjustments are thoroughly checked and corrected before the TV outgoing. Therefore the TV should operate normally and deliver proper colour pictures upon installation. However, several minor adjustments may be required depending on the particular location where the TV is operated. This TV is shipped completely in carton. Carefully take out the TV from the carton and remove all packing materials. Connect the power cord into a 120V AC, 60Hz two-pin power outlet. Turn on the TV. Check and adjust all the customer controls such as brightness, contrast and colour to obtain natural colour pictures.

2. Automatic Degaussing

A degaussing coil is mounted around the CRT so that external degaussing after moving the TV is generally unnecessary, providing it is properly degaussed upon installation. The degaussing coil operates in about 1 second after power on. If the set is moved or faced to a different direction, the power switch must be switched off for at least 30 minutes in order that the automatic degaussing circuit operates properly. Should the chassis or parts of the cabinet become magnetized to cause poor colour purity, use an external-degaussing coil. Slowly move the degaussing coil around the screen, the sides and front of the TV and slowly withdraw the coil to a distance of about 2m before unplug it. If colour shading still exists, perform the Colour Purity Adjustment and Convergence Adjustment procedures.

3. Supply Voltage Adjustment

Caution: +B voltage has close relation to high voltage. To avoid X-ray radiation, +B voltage should be +130V.

- 1) Set RP551 to the mechanical center and AC power supply to $120\pm 2V$.
- 2) Connect a digital voltmeter to two pins of C561, and then turn on the TV.
- 3) Receive Philips test pattern signals.
- 4) Adjust RV801 to make the voltmeter read $130\pm 1V$.

4. High Voltage Inspection

Caution: No high voltage adjustment should be done in the chassis.

- 1) Connect a precise high voltmeter to the second anode of the CRT.
- 2) Turn on the TV and set the brightness and contrast to minimum (i.e. set beam current of the CRT to zero).
- 3) The high voltage tested should be $21\pm 1.2KV$.
- 4) Set the brightness to minimum or maximum, and ensure high voltage not beyond limitation of 23KV in any case.

CIRCUIT ADJUSTMENTS (continued)

5. Focus Adjustment

- 1) Use the remote control to set the contrast to maximum and the brightness, chroma to medium.
- 2) Set H. V. lines near Philips pattern center to thinnest with the FCB on the FBT. After finishing adjustment, ensure that no poor focusing exists near the center or around of the frame.

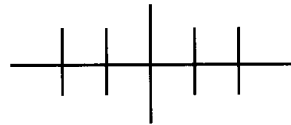

Before Adjusting



After Adjusting

SET-UP ADJUSTMENTS

- The following adjustments should be made when a complete realignment is required or a new CRT is installed. Perform the adjustments in order as follows.

1. Colour purity
2. Convergence
3. White Balance

Note:

The purity/convergence magnet assembly and rubber wedges need mechanical positioning. Refer to Fig. 9.

1. Colour Purity Adjustment

Note:

Before attempting any purity adjustment, the TV should be operated for at least 15 minutes.

- 1) Demagnetize the CRT and cabinet using a degaussing coil.
- 2) Set the brightness and contrast to maximum.
- 3) Receive the green raster test signals.
- 4) Loosen the clamp screw holding the deflection yoke and slide it backward or forward to display vertical green belt (zone) on the screen.
- 5) Remove the rubber wedge.
- 6) Rotate and spread the tabs of the purity magnet around the neck of the CRT until the green belt is on the centre of the screen.
- 7) Slowly move the deflection yoke forward or backward until a uniform green screen is obtained.
Tighten the clamp screw of the yoke temporarily.
- 8) Check purity of the red and blue raster.

SET-UP ADJUSTMENTS (continued)

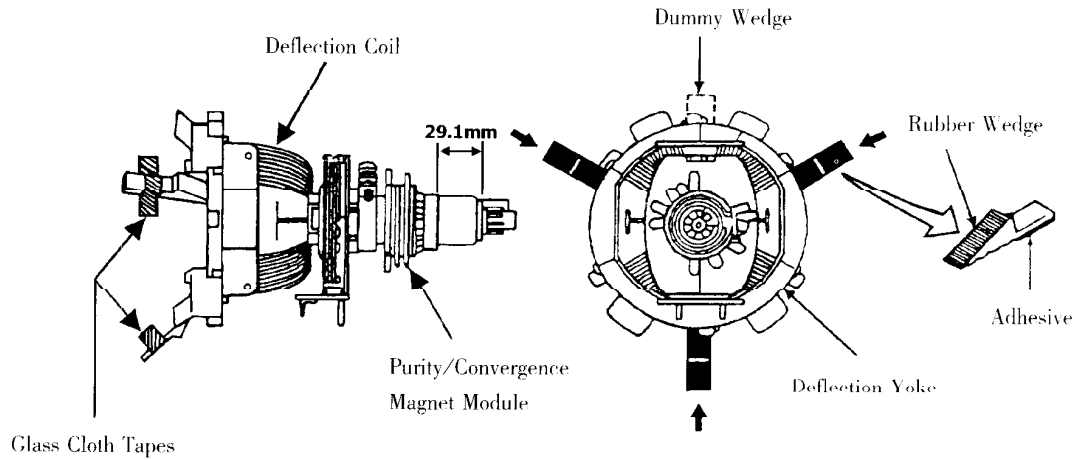

Fig. 9

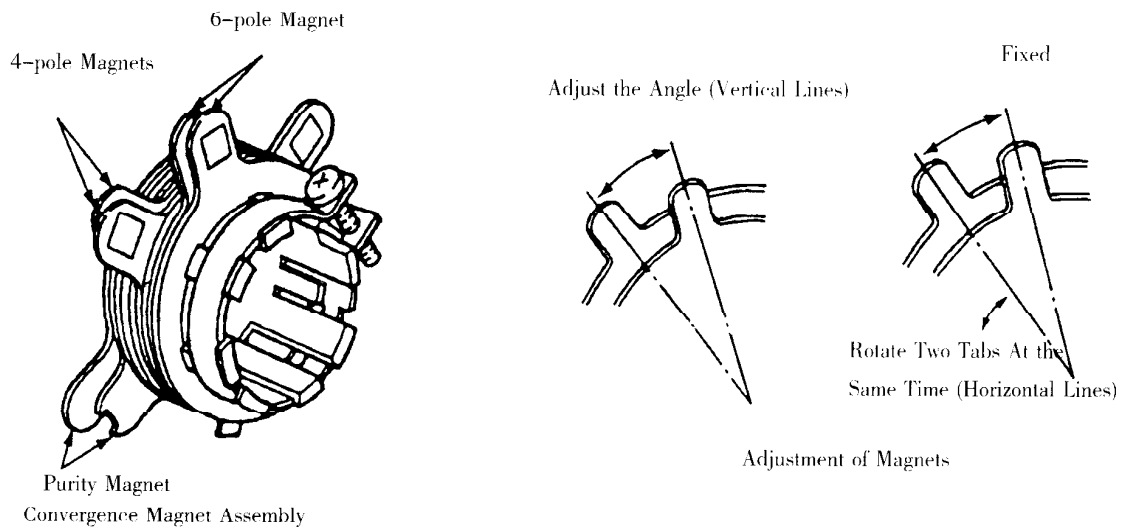

Fig. 10

2. Convergence Adjustment

Note:

Before attempting any convergence adjustment, the TV should be operated for at least 15 minutes.

- Center convergence adjustment
- 1) Receive the grille test pattern signals.
- 2) Set the brightness and contrast propely.
- 3) Adjust two tabs of the 4-pole magnet to change the angle between them and red and blue vertical lines are superimposed on the center area of the screen.
- 4) Turn both tabs at the same time keeping the angle constant to superimpose red and blue horizontal lines on the center of the screen.
- 5) Adjust two tabs of 6-pole magnet to superimpose red/blue line and green line. Adjusting the angle affects the vertical lines and rotating both magnets affects the horizontal lines.

SET-UP ADJUSTMENTS (continued)

6) Repeat steps 3)~5) keeping in mind red, green and blue movement. 4-pole magnet and 6-pole magnet interact each other, resulting in complicating and dot movement.

• Circumference convergence adjustment

- 1) Loosen the clamping screw of the deflection yoke slightly to allow it to tilt.
- 2) Temporarily put a wedge as shown in Fig. 9. (Do not remove cover paper on adhesive part of the wedge.)
- 3) Tilt front of the deflection yoke up or down to obtain better convergence in circumference.

Push the mounted wedge into the space between the CRT and yoke to fix the yoke temporarily.

- 4) Put other wedge into bottom space and remove the cover paper to stick.
- 5) Tilt front of the deflection yoke right or left to obtain better convergence in circumference.
- 6) Keep the deflection yoke position and put another wedge in either upper space. Remove cover paper and stick the wedge on the CRT to fix the yoke.
- 7) Detach the temporarily mounted wedge and put it in another upper space. Stick it on the CRT to fix the yoke.
- 8) After fixing three wedges, recheck overall convergence.

Tighten the screw firmly to fix the yoke and check if the yoke is fixed.

- 9) Stick three adhesive tapes on wedges as shown in Fig. 9.

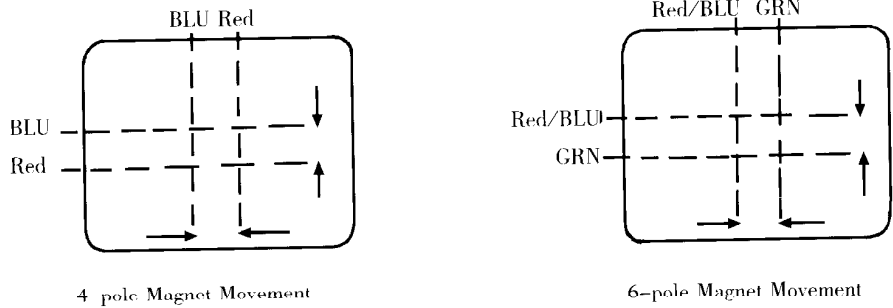

Center Convergence by Convergence Magnets

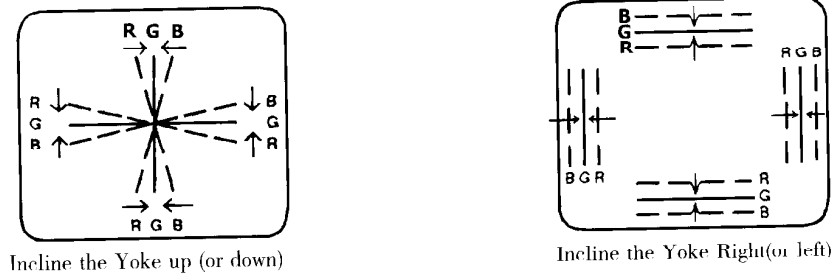

Circumference Convergence by DEF Yoke

Fig. 11

SERVICE MODE AND BUS DATA

1. How to Enter the Service Mode with the Remote Control

- 1) Decrease volume to 0.
- 2) Press the MUTE button on the remote control and VIDEO button on the TV at the same time.
- 3) Adjust the TV with the MENU SELECT buttons on the remote control.
- 4) Press the  button on the remote control to quit the Service mode.

2. Bus Data

MENU. 00	MENU. 01
V.POS /50H 39	SUB-BRIGHT 63
H.PHSE /50H 9	SUB-CONT 45
V.SIZE /50H 78	V.KILL 0
V.POS /60H 32	RF.AGC 15
H.PH /60H 12	R.BIAS 60
V.SIZE /60H 93	G.BIAS 120
V.SC 4	B.BIAS 60
V.LINE 18	R.DRIVE 90
V.SIZE CMP 7	G.DRIVE 15
	B.DRIVE 90
MENU. 02	MENU. 03
H.AFC GAIN 0	FM.MUTE 0
H.BLK.L 4	AUD.MUTE 0
H.BLK.R 3	VIDEO.MUTE 0
CROS.BIW 0	SND.TRAP 0
VIDEO.LVL 4	
FM.LEVEL 16	
MENU. 04	MENU. 05
SUB.COLOR 31	BLINK.DEF 0
SUB.TINT 31	BLK.ST.DEF 0
S.SHARP 32	FBP.BLK.SW 0
CORING 1	FILT.SYS 0
C.EXT 0	VOL.FIL 0
C.BYPASS 0	VIF.SYS.SW 0
C.KILL ON 0	VIDEO SW 0

SERVICE MODE AND BUS DATA (continued)

MENU. 06		MENU. 07	
R/G. ANGLE	9	BRT ABL.TH	7
GRAY MOD	1	EM.ABL.OEF	1
V.SEPUP	0	BRT.ABL.DF	
B.GAM.SEL	3		0
RG.GAM.DEP	1	MID.STP DF	1
MENU. 08		MENU.09	
DIGITAL OSD	0	H.FREQ	16
OSD.CONT	1	C.KILL.OFF	0
OSD H.POS	22	AUDIO.SW	1
MENU. 10		T.DISBLE	1
OPT.TV.AV	1		
OPT.COLOR	0		
OPT.V-CHIP	1		
OPT.CCD	1		
OPT.CLOCK	1		
SRCH SPEED	0		
ROM CORREC	0		

Notes:

- ① The data sheet may differ dependent on different models.
- ② The data sheet may differ dependent on different CRTs for the same model.

3. Service Mode Adjustment

1) Sub-brightness

- a) Receive colour signals.
- b) Set the contrast to maximum and brightness to medium.
- c) Set the chroma to medium.

Enter the TV to the Service mode. Select "SUB-BRIGHT" by pressing the ←/→ buttons on the remote control, and set the data to 31 by pressing the data adjustment buttons. Operate the TV for 5 minutes in the mode.

- d) Adjust the sub-bright data until blurry picture does not appear on the high bright area of the screen and too dim picture not on the low-bright area.
- e) Set the contrast and brightness to maximum or minimum, and then test normal picture alternation.
- f) If the picture does not become dark when the contrast and brightness are set to minimum, or not become bright when set to maximum, then adjust the sub-bright data to get normal picture.

SERVICE MODE AND BUS DATA (continued)

2) White balance adjustment

- a) Turn on the TV and preheat it for over 7 minutes.
- b) Use the remote control to set the contrast to maximum and the brightness to medium. Set the chroma to minimum.
- c) Enter the TV to the Service mode, and set the following data without changing other items.

R-DRIVE..... 90

G-DRIVE..... 15

B-DRIVE..... 90

- d) Pull out the external antenna and press the MUTE button once on the remote control until a right horizontal line appears on the screen. Adjust the R-DRV data to get $160V \pm 0.5$ green gun voltage across the CRT RGB PCB.
- e) Adjust the G-DRV and B-DRV data according to Step 4 so that the bright horizontal line turns to yellow, then to white.

3) Horizontal centering adjustment

Enter the TV to the Service mode and receive Philips test pattern signals. Select "H.PH/60H" by pressing the ←/→ buttons on the remote control, and adjust horizontal picture position in the centre of screen by pressing the data adjustment buttons.

4) Vertical centering adjustment

Enter the TV to the Service mode and receive Philips test pattern signals. Select "V.POS/60H" by pressing the ←/→ buttons on the remote control, and adjust vertical picture position in the centre of screen by pressing the data adjustment buttons.

5) Vertical amplitude adjustment

Enter the TV to the Service mode and receive grille test pattern signals. Select "V.SIZE" by pressing the ←/→ buttons on the remote control, and adjust vertical amplitude by pressing the data adjustment buttons so that vertical amplitude is not enough. Continue to adjust vertical amplitude by pressing the data adjustment button until the first bar on grille signals touches edge of the screen.

TROUBLESHOOTING FLOW CHARTS

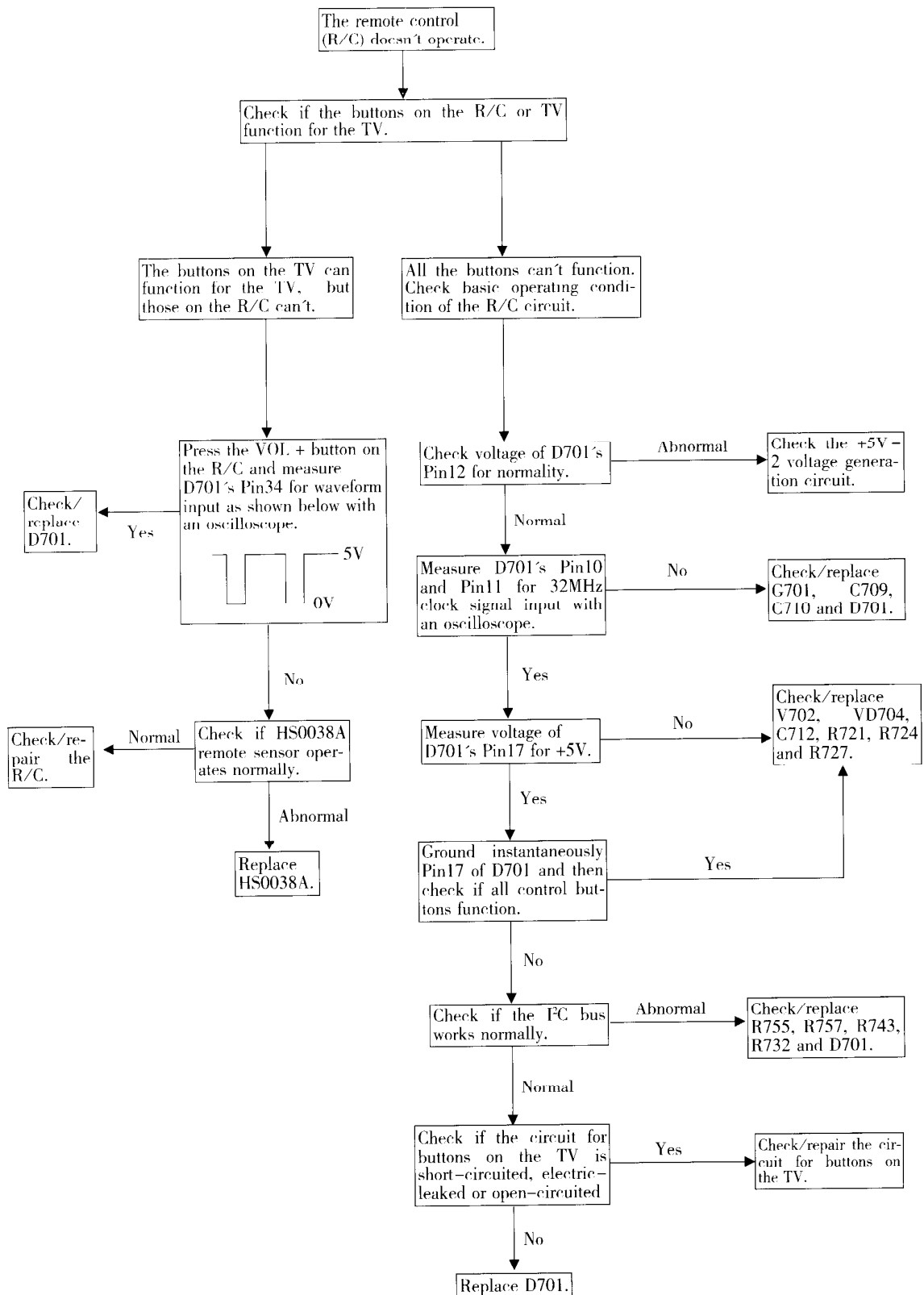

TROUBLESHOOTING FLOW CHARTS (continued)

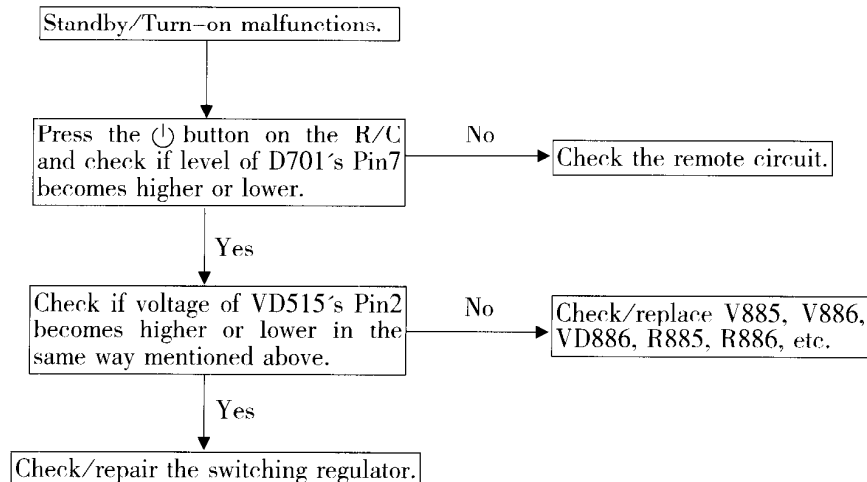
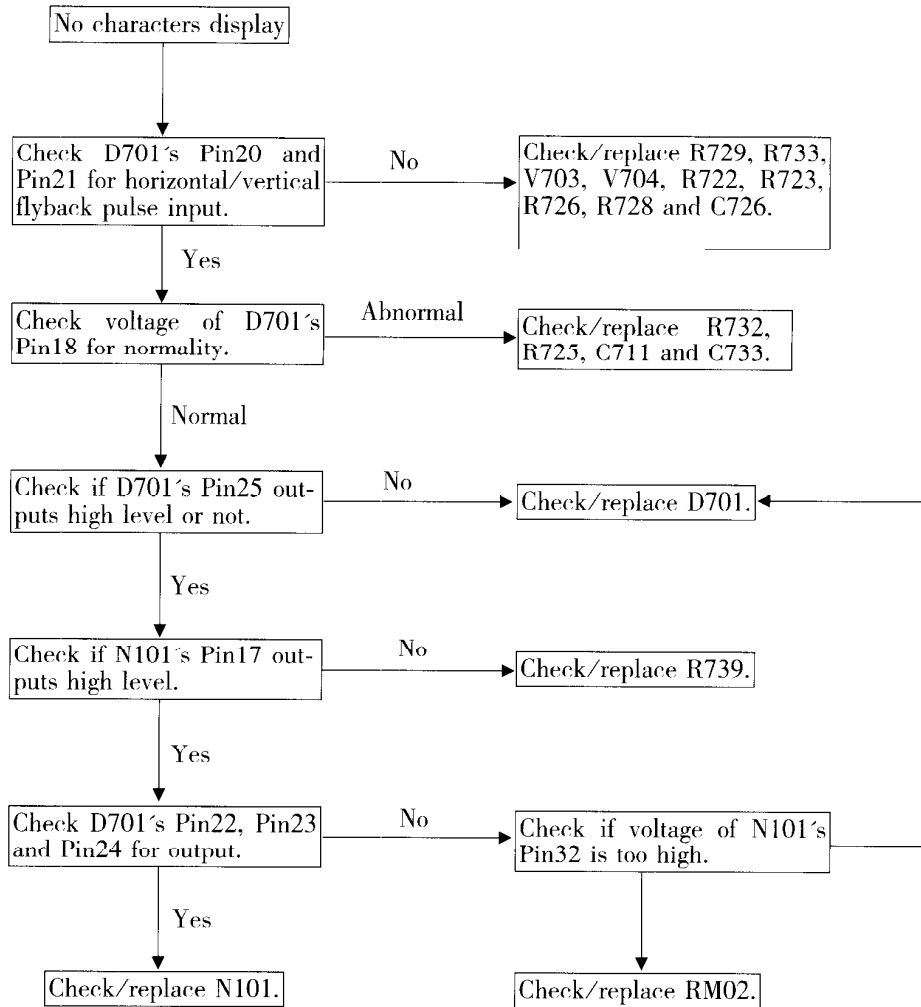

TROUBLESHOOTING FLOW CHARTS (continued)

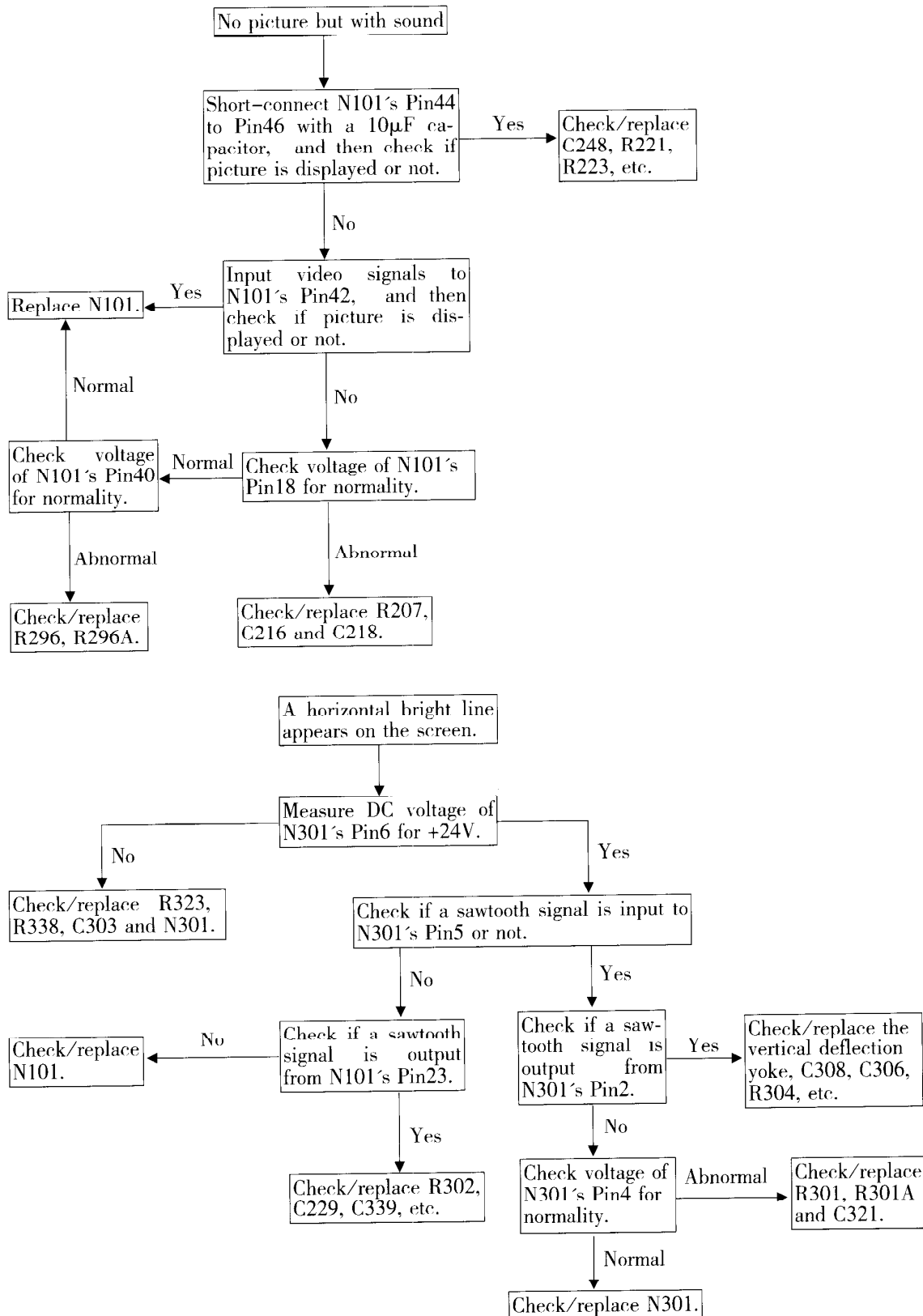

TROUBLESHOOTING FLOW CHARTS (continued)

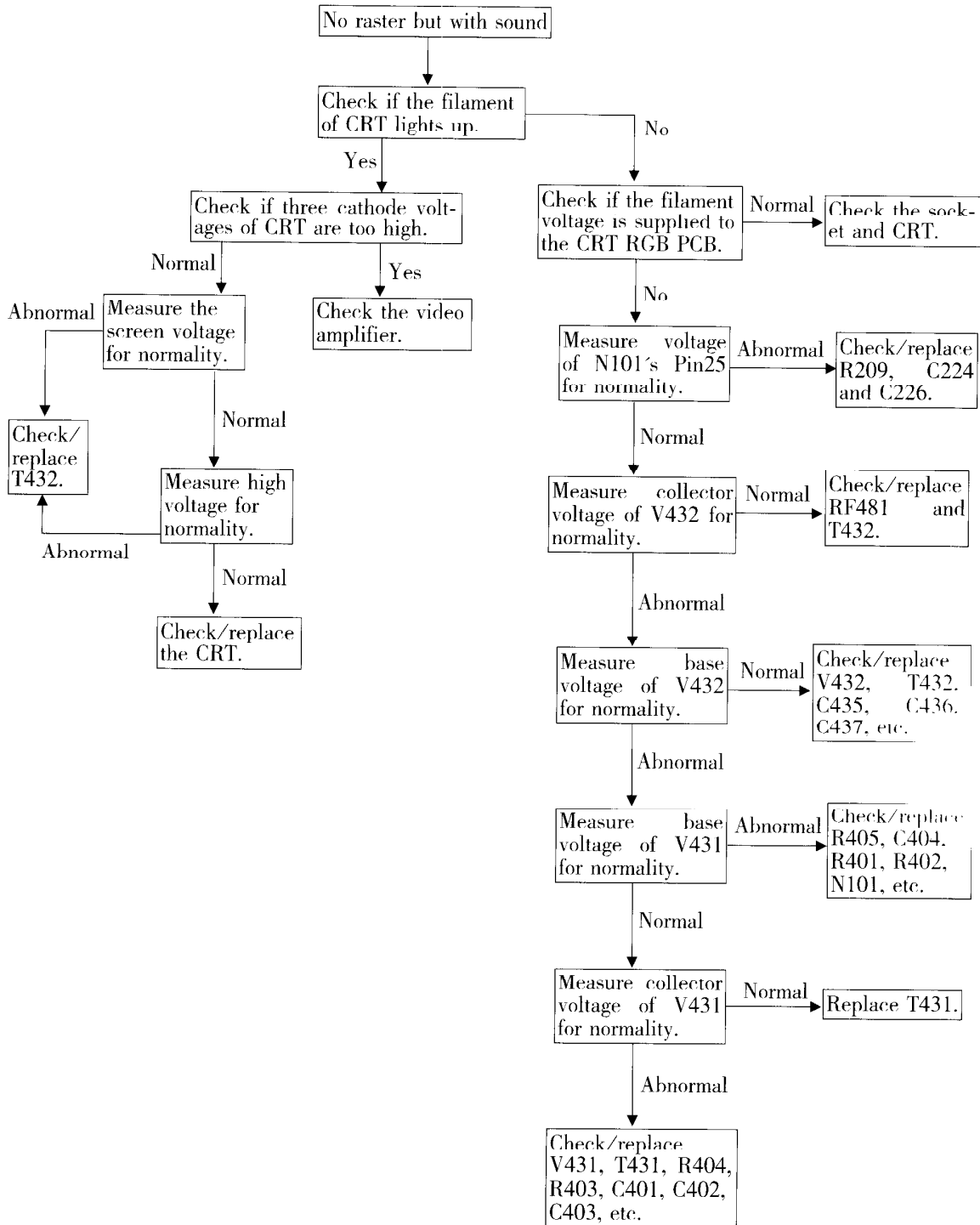

TROUBLESHOOTING FLOW CHARTS (continued)

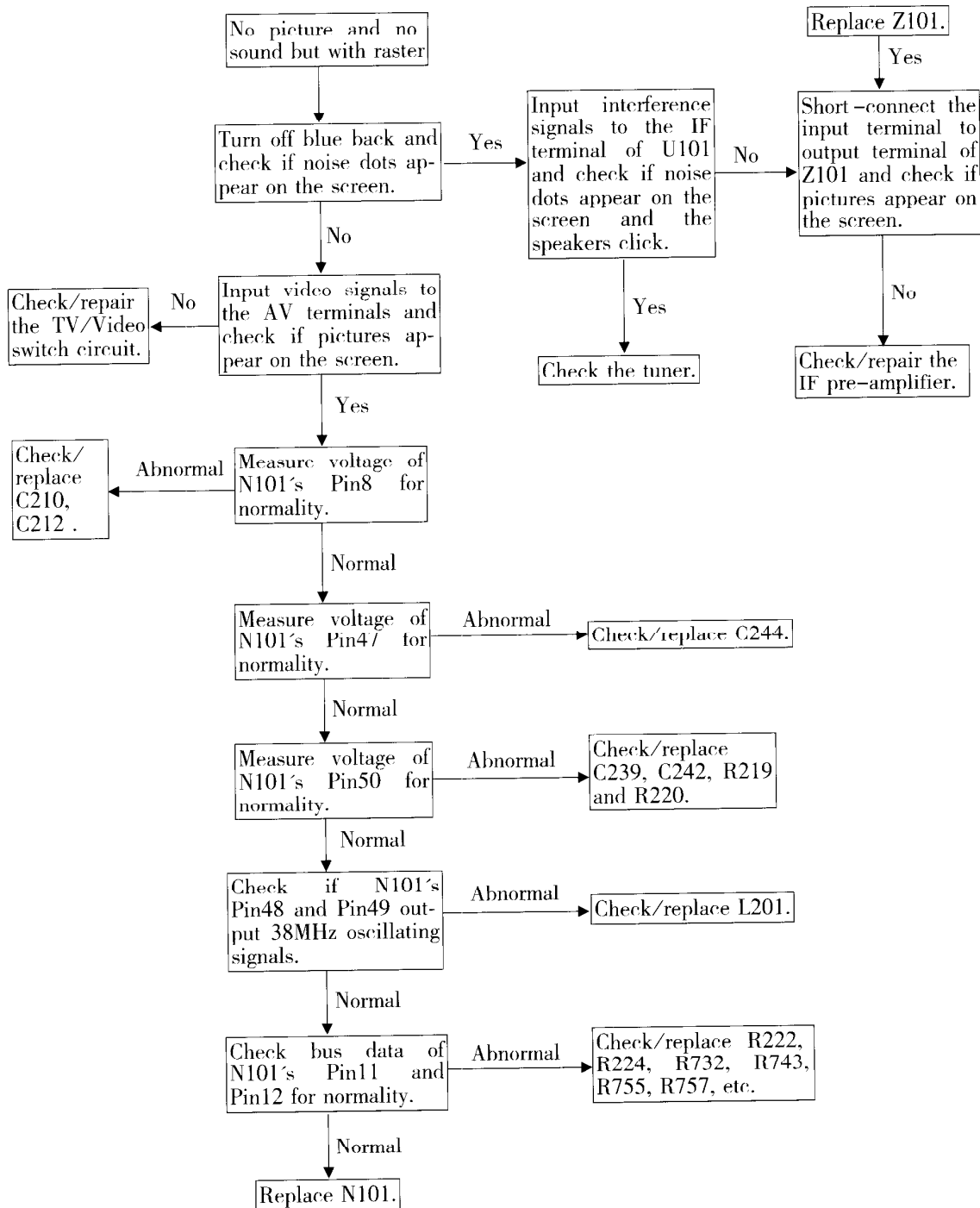

TROUBLESHOOTING FLOW CHARTS (continued)

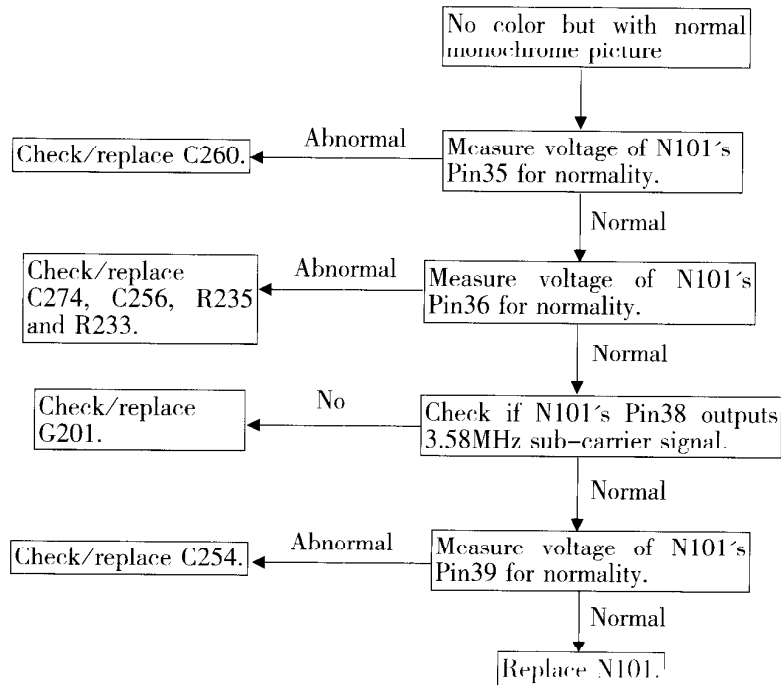
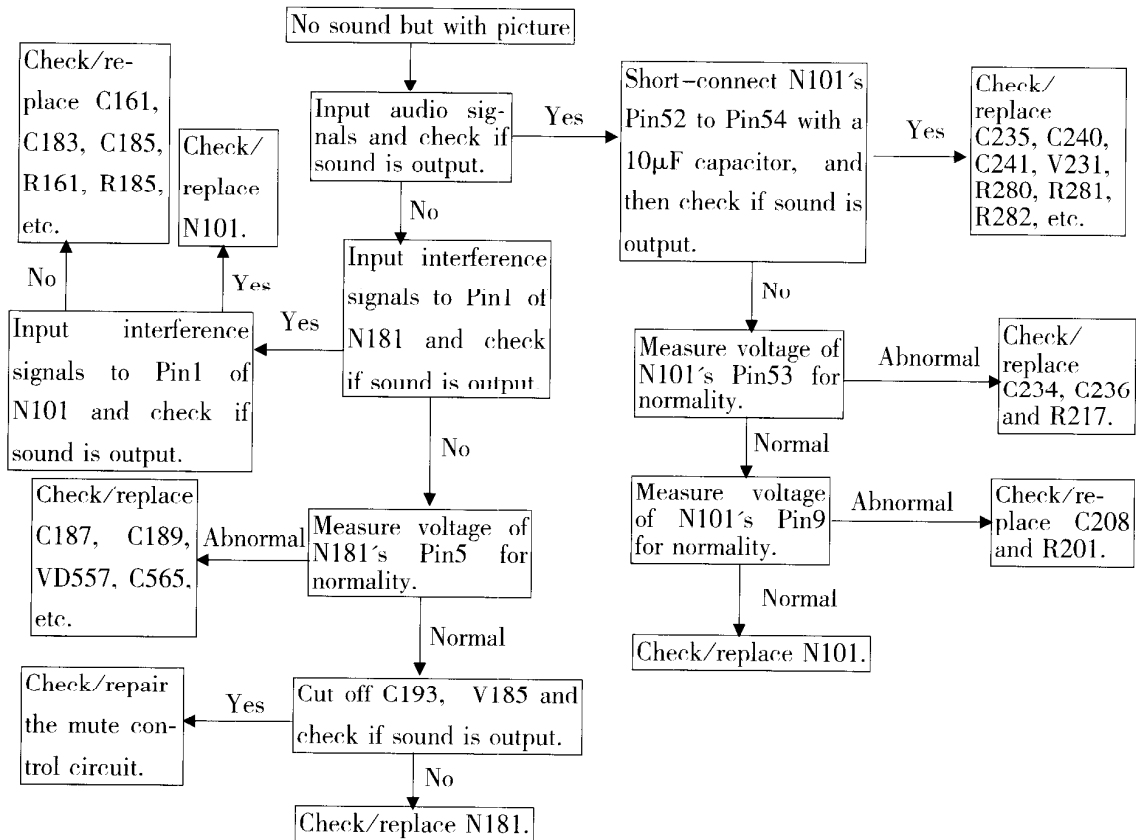

TROUBLESHOOTING FLOW CHARTS (continued)

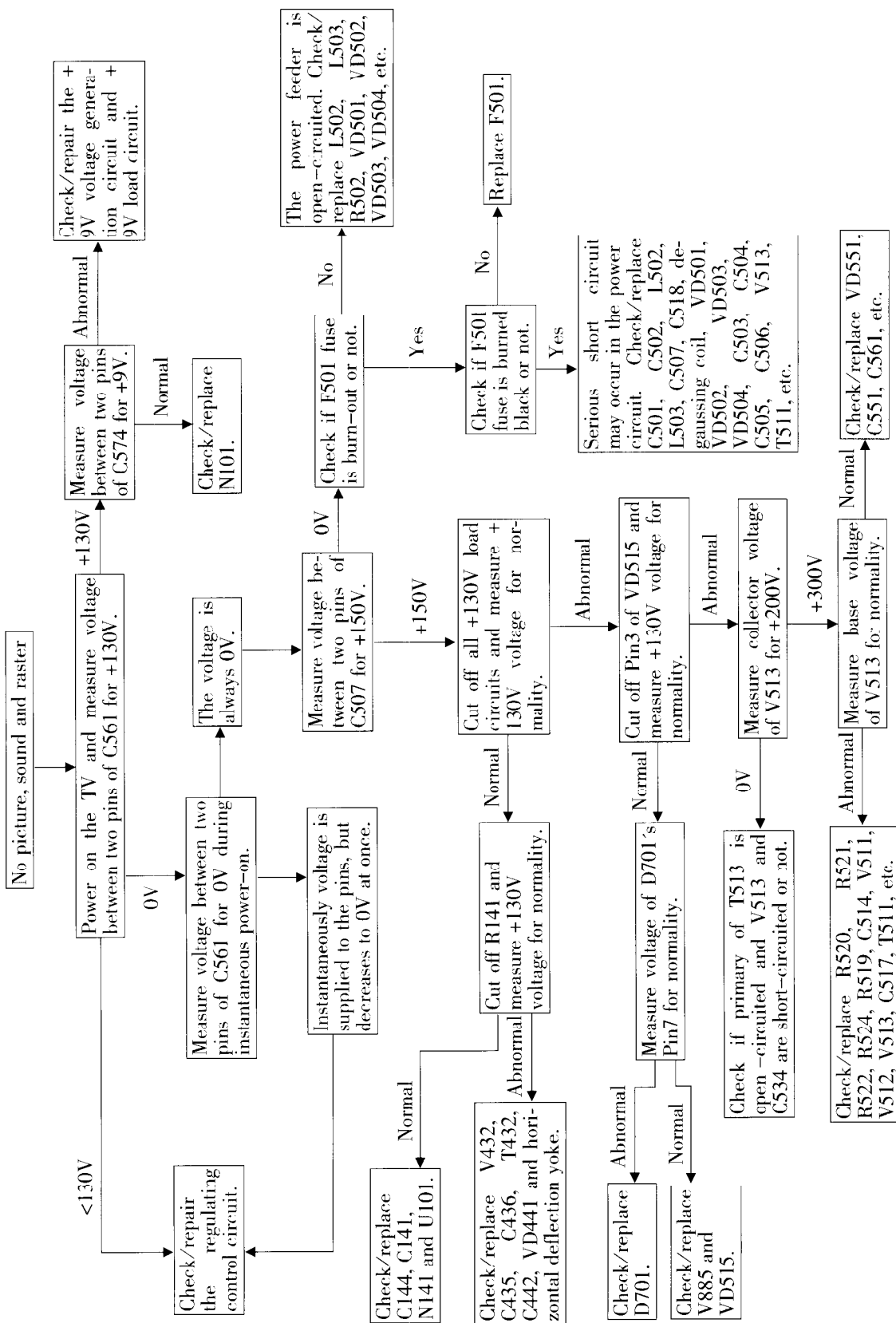

PARTS LIST

Position	Parts	Type
		Parts on Main PCB
R309	Carbon film resistor	RT13-0.166W-1ΩJ
R519	Carbon film resistor	RT13-0.166W-22ΩJ
R207	Carbon film resistor	RT13-0.166W-56ΩJ
R108	Carbon film resistor	RT13-0.166W-68ΩJ
R122	Carbon film resistor	RT13-0.166W-100ΩJ
R123	Carbon film resistor	RT13-0.166W-100ΩJ
R707	Carbon film resistor	RT13-0.166W-100ΩJ
R743	Carbon film resistor	RT13-0.166W-100ΩJ
R744	Carbon film resistor	RT13-0.166W-100ΩJ
R802	Carbon film resistor	RT13-0.166W-100ΩJ
R802A	Carbon film resistor	RT13-0.166W-100ΩJ
R101	Carbon film resistor	RT13-0.166W-120ΩJ
R209	Carbon film resistor	RT13-0.166W-150ΩJ
R219	Carbon film resistor	RT13-0.166W-150ΩJ
R222	Carbon film resistor	RT13-0.166W-220ΩJ
R224	Carbon film resistor	RT13-0.166W-220ΩJ
R732	Carbon film resistor	RT13-0.166W-220ΩJ
R716	Carbon film resistor	RT13-0.166W-270ΩJ
R730	Carbon film resistor	RT13-0.166W-270ΩJ
R583	Carbon film resistor	RT13-0.166W-330ΩJ
R741	Carbon film resistor	RT13-0.166W-470ΩJ
R742	Carbon film resistor	RT13-0.166W-470ΩJ
R120	Carbon film resistor	RT14-0.25W-680ΩJ
R405	Carbon film resistor	RT14-0.25W-680ΩJ
R746	Carbon film resistor	RT14-0.25W-680ΩJ
R747	Carbon film resistor	RT14-0.25W-680ΩJ
R748	Carbon film resistor	RT14-0.25W-680ΩJ
R185	Carbon film resistor	RT13-0.166W-820ΩJ
R296A	Carbon film resistor	RT13-0.166W-820ΩJ
R280	Carbon film resistor	RT13-0.166W-1KΩJ
R217	Carbon film resistor	RT13-0.166W-1KΩJ
R401	Carbon film resistor	RT13-0.166W-1KΩJ
R791	Carbon film resistor	RT13-0.166W-1KΩJ
R806	Carbon film resistor	RT13-0.166W-1KΩJ
R812	Carbon film resistor	RT13-0.166W-1KΩJ
RS13	Carbon film resistor	RT13-0.166W-1KΩJ
RS14	Carbon film resistor	RT13-0.166W-1KΩJ
RS15	Carbon film resistor	RT13-0.166W-1KΩJ
R221	Carbon film resistor	RT13-0.166W-1KΩJ
R223	Carbon film resistor	RT13-0.166W-1KΩJ
K143	Carbon film resistor	RT13-0.166W-1KΩJ

PARTS LIST (continued)

Position	Parts	Type
R517	Carbon film resistor	RT13-0.166W-1K ΩJ
RM01	Carbon film resistor	RT13-0.166W-1K ΩJ
R106	Carbon film resistor	RT13-0.166W-1.2K ΩJ
R107	Carbon film resistor	RT13-0.166W-1.2K ΩJ
R296	Carbon film resistor	RT13-0.166W-1.2K ΩJ
R721	Carbon film resistor	RT13-0.166W-1.5K ΩJ
R523	Carbon film resistor	RT13-0.166W-1.5K ΩJ
R130	Carbon film resistor	RT13-0.166W-1.8K ΩJ
R424	Carbon film resistor	RT13-0.166W-1.8K ΩJ
R423	Carbon film resistor	RT13-0.166W-1.8K ΩJ
R215	Carbon film resistor	RT13-0.166W-2.2K ΩJ
R301A	Carbon film resistor	RT13-0.166W-2.2K ΩJ
R307	Carbon film resistor	RT13-0.166W-2.2K ΩJ
R402	Carbon film resistor	RT13-0.166W-2.2K ΩJ
R728	Carbon film resistor	RT13-0.166W-2.2K ΩJ
R526	Carbon film resistor	RT13-0.166W-2.7K ΩJ
R301B	Carbon film resistor	RT13-0.166W-2.7K ΩJ
R228	Carbon film resistor	RT13-0.166W-2.7K ΩJ
R211	Carbon film resistor	RT13-0.166W-3.3K ΩJ
R249	Carbon film resistor	RT13-0.166W-3.3K ΩJ
R736	Carbon film resistor	RT13-0.166W-3.3K ΩJ
R737	Carbon film resistor	RT13-0.166W-3.3K ΩJ
R738	Carbon film resistor	RT13-0.166W-3.3K ΩJ
R739	Carbon film resistor	RT13-0.166W-3.3K ΩJ
R749	Carbon film resistor	RT13-0.166W-3.3K ΩJ
R803	Carbon film resistor	RT13-0.166W-3.9K ΩJ
R105	Carbon film resistor	RT13-0.166W-4.7K ΩJ
R186	Carbon film resistor	RT13-0.166W-4.7K ΩJ
R188	Carbon film resistor	RT13-0.166W-4.7K ΩJ
R553	Carbon film resistor	RT13-0.166W-4.7K ΩJ
R727	Carbon film resistor	RT13-0.166W-4.7K ΩJ
R755	Carbon film resistor	RT13-0.166W-4.7K ΩJ
R757	Carbon film resistor	RT13-0.166W-4.7K ΩJ
R760	Carbon film resistor	RT13-0.166W-4.7K ΩJ
R778	Carbon film resistor	RT13-0.166W-4.7K ΩJ
R712	Carbon film resistor	RT13-0.166W-4.7K ΩJ
R715	Carbon film resistor	RT13-0.166W-4.7K ΩJ
R302	Carbon film resistor	RT13-0.166W-5.6K ΩJ
R511	Carbon film resistor	RT13-0.166W-5.6K ΩJ
R724	Carbon film resistor	RT13-0.166W-8.2K ΩJ
R126	Carbon film resistor	RT13-0.166W-10K ΩJ
R127	Carbon film resistor	RT13-0.166W-10K ΩJ
R161	Carbon film resistor	RT13-0.166W-10K ΩJ

PARTS LIST (continued)

Position	Parts	Type
R233A	Carbon film resistor	RT13-0.166W-10K Ω J
R281	Carbon film resistor	RT13-0.166W-10K Ω J
R282	Carbon film resistor	RT13-0.166W-10K Ω J
R416	Carbon film resistor	RT13-0.166W-10K Ω J
R586	Carbon film resistor	RT13-0.166W-10K Ω J
R710	Carbon film resistor	RT13-0.166W-10K Ω J
R726	Carbon film resistor	RT13-0.166W-10K Ω J
R729	Carbon film resistor	RT13-0.166W-10K Ω J
R733	Carbon film resistor	RT13-0.166W-10K Ω J
R734	Carbon film resistor	RT13-0.166W-10K Ω J
R792	Carbon film resistor	RT13-0.166W-10K Ω J
R801	Carbon film resistor	RT13-0.166W-10K Ω J
R815	Carbon film resistor	RT13-0.166W-10K Ω J
R305	Carbon film resistor	RT13-0.166W-12K Ω J
R313	Carbon film resistor	RT13-0.166W-12K Ω J
R522	Carbon film resistor	RT13-0.166W-15K Ω J
R818	Carbon film resistor	RT13-0.166W-15K Ω J
R711	Carbon film resistor	RT13-0.166W-18K Ω J
R714	Carbon film resistor	RT13-0.166W-18K Ω J
R515	Carbon film resistor	RT13-0.166W-22K Ω J
R556	Carbon film resistor	RT13-0.166W-22K Ω J
R235	Carbon film resistor	RT13-0.166W-27K Ω J
R201	Carbon film resistor	RT13-0.166W-27K Ω J
R233	Carbon film resistor	RT13-0.166W-27K Ω J
R131	Carbon film resistor	RT13-0.166W-33K Ω J
R585	Carbon film resistor	RT13-0.166W-47K Ω J
R561	Carbon film resistor	RT13-0.166W-51K Ω J
R562	Carbon film resistor	RT13-0.166W-51K Ω J
R314	Carbon film resistor	RT13-0.166W-56K Ω J
R132	Carbon film resistor	RT13-0.166W-100K Ω J
R203	Carbon film resistor	RT13-0.166W-100K Ω J
R205	Carbon film resistor	RT13-0.166W-100K Ω J
R225	Carbon film resistor	RT13-0.166W-100K Ω J
R723	Carbon film resistor	RT13-0.166W-100K Ω J
R759	Carbon film resistor	RT13-0.166W-100K Ω J
R426	Carbon film resistor	RT13-0.166W-150K Ω J
R554	Carbon film resistor	RT13-0.166W-150K Ω J
R220	Carbon film resistor	RT13-0.166W-220K Ω J
R440	Carbon film resistor	RT13-0.166W-220K Ω J
R722	Carbon film resistor	RT13-0.166W-220K Ω J
R701	Carbon film resistor	RT13-0.166W-390K Ω J
R725	Carbon film resistor	RT13-0.166W-1M Ω J
R304	Carbon film resistor	RT15-0.5W-1 Ω J

SERVICE MANUAL

PARTS LIST (continued)

Position	Parts	Type
R415	Carbon film resistor	RT14-0.25W-15K Ω J
R323	Carbon film resistor	RT15-0.5W-150 Ω J
R403	Carbon film resistor	RT15-0.5W-1K Ω J
R338	Carbon film resistor	RT15-0.5W-1K Ω J
R555	Carbon film resistor	RT15-0.5W-47K Ω J
R245	Metal film resistor	RJ14-0.25W-4.7K Ω F
R310	Metal oxide film resistor	RY21-0.5W-220 Ω J
R441	Metal oxide film resistor	RY21-1W-1K Ω J
R581	Metal oxide film resistor	RY21-1W-2.2K Ω J
R581A	Metal oxide film resistor	RY21-1W-2.2K Ω J
R537	Metal oxide film resistor	RY21-2W-27 Ω J
R525	Metal oxide film resistor	RY21-2W-68 Ω J
R404	Metal oxide film resistor	RY21-2W-330 Ω J
R442	Metal oxide film resistor	RY21-2W-2.2K Ω J
R551	Metal oxide film resistor	RY21-2W-15K Ω J
R552	Metal oxide film resistor	RY21-2W-15K Ω J
R141	Metal oxide film resistor	RY21-2W-15K Ω J
R568	Metal oxide film resistor	RY21-2W-22K Ω J
R520	Solid resistor	RS11-0.5W-120K Ω K
R520	Solid resistor	RI40-0.5W-120K Ω K
R521	Solid resistor	RS11-0.5W-120K Ω K
R521	Solid resistor	RI40-0.5W-120K Ω K
R435	Wirewound resistor	RXG4-6W-8.2 Ω K
R524	Wirewound resistor	RXG4-6W-20 Ω J
R502	Wirewound resistor	RXG6-H2-10W-2.2 Ω J
RF565	Fuse resistor	RF10-2W-6.8 Ω J
RF569	Fuse resistor	RF10-2W-2.2 Ω J
RF481	Fuse resistor	RF11-1W-1.8 Ω J
RP551	Glass glazed potentiometer	WI06-2Y-0.125W-2K Ω -A
RT501A	Thermistor	232266296709(PH96709-7 Ω)
RV501B	Glass glazed resistor	VR68-1W-2.7M Ω J
RV501B	Glass glazed resistor	RI81-1W-2.7M Ω J
C710	Ceramic capacitor	CC1-63V-06a-C-15PFJ
C238	Ceramic capacitor	CC1-63V-06a-C-18PFJ
C709	Ceramic capacitor	CC1-63V-06a-C-18PFJ
C240	Ceramic capacitor	CC1-63V-06a-C-39PFJ
C239	Ceramic capacitor	CT1-63V-06a-2B4-470PFK
C108	Ceramic capacitor	CT1-63V-06a-2B4-1000PFK
C185	Ceramic capacitor	CT1-63V-06a-2B4-1000PFK
C234	Ceramic capacitor	CT1-63V-06a-2B4-1000PFK
C260	Ceramic capacitor	CT1-63V-06a-2B4-1000PFK
C301	Ceramic capacitor	CT1-63V-06a-2B4-1000PFK
C812	Ceramic capacitor	CT1-63V-06a-2B4-1000PFK

SERVICE MANUAL

PARTS LIST (continued)

Position	Parts	Type
C109	Ceramic capacitor	CT1-63V-06a-2B4-1500PFK
C110	Ceramic capacitor	CT1-63V-06a-2B4-1500PFK
C111	Ceramic capacitor	CT1-63V-06a-2B4-1500PFK
C416	Ceramic capacitor	CT1-63V-10a-2B4-3900PFK
C144	Ceramic capacitor	CT1-63V-08a-2F4-10nFZ
C201	Ceramic capacitor	CT1-63V-08a-2F4-10nFZ
C203	Ceramic capacitor	CT1-63V-08a-2F4-10nFZ
C205	Ceramic capacitor	CT1-63V-08a-2F4-10nFZ
C206	Ceramic capacitor	CT1-63V-08a-2F4-10nFZ
C210	Ceramic capacitor	CT1-63V-08a-2F4-10nFZ
C218	Ceramic capacitor	CT1-63V-08a-2F4-10nFZ
C226	Ceramic capacitor	CT1-63V-08a-2F4-10nFZ
C235	Ceramic capacitor	CT1-63V-08a-2F4-10nFZ
C243	Ceramic capacitor	CT1-63V-08a-2F4-10nFZ
C249	Ceramic capacitor	CT1-63V-08a-2F4-10nFZ
C255	Ceramic capacitor	CT1-63V-08a-2F4-10nFZ
C257	Ceramic capacitor	CT1-63V-08a-2F4-10nFZ
C513	Ceramic capacitor	CT1-63V-08a-2F4-10nFZ
C703	Ceramic capacitor	CT1-63V-08a-2F4-10nFZ
C708	Ceramic capacitor	CT1-63V-08a-2F4-10nFZ
C712	Ceramic capacitor	CT1-63V-08a-2F4-10nFZ
C713	Ceramic capacitor	CT1-63V-08a-2F4-10nFZ
C270	Ceramic capacitor	CT1-63V-08a-2F4-10nFZ
C321A	Ceramic capacitor	CC1-500V-06c-SL-18PFJ
C415	Ceramic capacitor	CT1-500V-06c-2B4-390PFK
C401	Ceramic capacitor	CT1-500V-10c-2B4-1000PFK
C402	Ceramic capacitor	CT1-500V-14c-2B4-3900PFK
C535	Ceramic capacitor	CT81-250V-2E4-2200PFM
C536	Ceramic capacitor	CT81-250V-2E4-2200PFM
C554	Ceramic capacitor	CT81-1KV-08c-2B4-470PFK
C503	Ceramic capacitor	CT81-1KV-10c-2B4-1000PFM
C504	Ceramic capacitor	CT81-1KV-10c-2B4-1000PFM
C505	Ceramic capacitor	CT81-1KV-10c-2B4-1000PFM
C506	Ceramic capacitor	CT81-1KV-10c-2B4-1000PFM
C518	Ceramic capacitor	CT81-1KV-10c-2B4-1000PFM
C552A	Ceramic capacitor	CT81-2KV-08c-2B4-220PFK
C551	Ceramic capacitor	CT81-2KV-10c-2B4-470PFK
C436	Ceramic capacitor	CT81-2KV-10c-2B4-470PFK
C516	Ceramic capacitor	CT81-2KV-12c-2B4-680PFK
C216	Aluminum electrolytic capacitor	CD110-16V-47 μ FM
C707	Aluminum electrolytic capacitor	CD110-16V-47 μ FM
C191	Aluminum electrolytic capacitor	CD110X-16V-100 μ FM
C212	Aluminum electrolytic capacitor	CD110X-16V-100 μ FM

SERVICE MANUAL

PARTS LIST (continued)

Position	Parts	Type
C805	Aluminum electrolytic capacitor	CD110X-16V-100 μ FM
C122	Aluminum electrolytic capacitor	CD110X-16V-470 μ FM
C250	Aluminum electrolytic capacitor	CD110X-16V-470 μ FM
C500	Aluminum electrolytic capacitor	CD110X-16V-470 μ FM
C538	Aluminum electrolytic capacitor	CD110X-16V-470 μ FM
C574	Aluminum electrolytic capacitor	CD110X-16V-470 μ FM
C564	Aluminum electrolytic capacitor	CD110X-16V-1000 μ FM
C186	Aluminum electrolytic capacitor	CD110X-25V-470 μ FM
C303	Aluminum electrolytic capacitor	CD110X-25V-470 μ FM
C189	Aluminum electrolytic capacitor	CD110X-25V-1000 μ FM
C565	Aluminum electrolytic capacitor	CD110X-25V-2200 μ FM
C403	Aluminum electrolytic capacitor	CD110X-35V-47 μ FM
C302	Aluminum electrolytic capacitor	CD110X-35V-100 μ FM
C306	Aluminum electrolytic capacitor	CD110X-35V-1000 μ FM
C563	Aluminum electrolytic capacitor	CD110X-35V-1000 μ FM
C242	Aluminum electrolytic capacitor	CD110-50V-0.47 μ FM
C244	Aluminum electrolytic capacitor	CD110-50V-0.47 μ FM
C256	Aluminum electrolytic capacitor	CD110-50V-0.47 μ FM
C711	Aluminum electrolytic capacitor	CD110-50V-0.47 μ FM
C161	Aluminum electrolytic capacitor	CD110-50V-1 μ FM
C208	Aluminum electrolytic capacitor	CD110-50V-1 μ FM
C230	Aluminum electrolytic capacitor	CD110-50V-1 μ FM
C248	Aluminum electrolytic capacitor	CD110-50V-1 μ FM
C293	Aluminum electrolytic capacitor	CD110-50V-1 μ FM
C321	Aluminum electrolytic capacitor	CD110-50V-1 μ FM
C444	Aluminum electrolytic capacitor	CD110-50V-1 μ FM
C236	Aluminum electrolytic capacitor	CD110-50V-1 μ FM
C808	Aluminum electrolytic capacitor	CD110-50V-1 μ FM
C802	Aluminum electrolytic capacitor	CD110-50V-1 μ FM
C131	Aluminum electrolytic capacitor	CD110-50V-2.2 μ FM
C141	Aluminum electrolytic capacitor	CD110-50V-4.7 μ FM
C183	Aluminum electrolytic capacitor	CD110-50V-4.7 μ FM
C304	Aluminum electrolytic capacitor	CD110-50V-4.7 μ FM
C193	Aluminum electrolytic capacitor	CD110-50V-10 μ FM
C224	Aluminum electrolytic capacitor	CD110-50V-10 μ FM
C241	Aluminum electrolytic capacitor	CD110-50V-10 μ FM
C246	Aluminum electrolytic capacitor	CD110-50V-10 μ FM
C254	Aluminum electrolytic capacitor	CD110-50V-10 μ FM
C705	Aluminum electrolytic capacitor	CD110-50V-10 μ FM
C733	Aluminum electrolytic capacitor	CD110-50V-10 μ FM
C777	Aluminum electrolytic capacitor	CD110-50V-10 μ FM
C801	Aluminum electrolytic capacitor	CD110-50V-10 μ FM
C803	Aluminum electrolytic capacitor	CD110-50V-10 μ FM

PARTS LIST (continued)

Position	Parts	Type
C443	Aluminum electrolytic capacitor	CD81-160V-4.7 μ FM
C561	Aluminum electrolytic capacitor	CD288-160V-220 μ FM
C555A	Aluminum electrolytic capacitor	CD110X-250V-22 μ FM
JM02	Aluminum electrolytic capacitor	CD71-50V-1 μ FM
C422	Aluminum electrolytic capacitor	CD71-50V-4.7 μ FM
C507	Aluminum electrolytic capacitor	CD293-200V-270 μ FM
C229	Polyester film capacitor	CL12 50V 0.056 μ FK
C229	Polyester film capacitor	CL11X-50V-0.056 μ FK
C274	Polyester film capacitor	CL12-50V-0.056 μ FK
C274	Polyester film capacitor	CL11X-50V-0.056 μ FK
C404	Polyester film capacitor	CL12-50V-0.056 μ FK
C404	Polyester film capacitor	CL11X-50V-0.056 μ FK
C187	Polyester film capacitor	CL12-50V-0.1 μ FK
C187	Polyester film capacitor	CL11X-50V-0.1 μ FK
C214	Polyester film capacitor	CL12-50V-0.1 μ FK
C214	Polyester film capacitor	CL11X-50V-0.1 μ FK
C308	Polyester film capacitor	CL12-100V-0.033 μ FK
C308	Polyester film capacitor	CL11X-100V-0.033 μ FK
C307	Polyester film capacitor	CL12-100V-0.1 μ FK
C307	Polyester film capacitor	CL11X-100V-0.1 μ FK
C204	Polyester film capacitor	CL21X-50V-0.015 μ FJ
C228	Polyester film capacitor	CL21X-50V-0.015 μ FJ
C515	Polyester film capacitor	CL21X-50V-0.015 μ FJ
C112	Polyester film capacitor	CL21X-50V-0.022 μ FJ
C202	Polyester film capacitor	CL21X-50V-0.022 μ FJ
C726	Polyester film capacitor	CL21X-50V-0.033 μ FJ
C517	Polyester film capacitor	CL21X-50V-0.033 μ FJ
C514	Polyester film capacitor	CL21X-50V-0.1 μ FK
C220	Polyester film capacitor	CL21X-50V-0.22 μ FK
C222	Polyester film capacitor	CL21X-50V-0.47 μ FK
C222	Polyester film capacitor	CL21X-50V-0.47 μ FK
C437	Polyester film capacitor	CL21X-50V-0.47 μ FK
C437	Polyester film capacitor	CL21X-50V-0.47 μ FK
C440	Polypropylene capacitor	CBB13-400V-0.39 μ FJ
C440	Polypropylene capacitor	CBB13-400V-0.39 μ FJ
C435	Polypropylene capacitor	CBB81-1.6KV-6800PFJ
C501	Polypropylene capacitor	MKP3355-275V-0.1 μ FM
C502	Polypropylene capacitor	MKP3355-275V-0.1 μ FM
L104	Fixed inductor	LGB0606-1 μ HJ
L202	Fixed inductor	LGB0606-10 μ HK
L204	Fixed inductor	LGB0606-10 μ HK
L705	Fixed inductor	LGB0606-10 μ HK

PARTS LIST (continued)

Position	Parts	Type
L287	Fixed inductor	LGB0606-15 μ HJ
L431	Feed-through inductor	ZZ008
L432	Feed-through inductor	ZZ008
L502	Filtering inductor	LCL-F15(JUB4.757.001)
L503	Filtering inductor	LCL-F16(JUB4.757.002)
L442	Horizontal amplitude coil	TLN0028A
L441	Horizontal linearity inductor	HXT 39
T401	Line drive transformer	BCT-5(JU4.739.031)
T401	Line drive transformer	AD-0001
L201	IF transformer	ST6030
T511	Switch transformer	BCK-24308L(JUB4.726.015)
T432	FBT	BSC60T
VD704	Diode	W05Z3.6A
VD704	Diode	HZ4C3
VD704	Diode	RD3.6EL
VD251	Diode	W05Z5.6C
VD251	Diode	MTZJ5.6C
VD533	Diode	W05Z5.6C
VD533	Diode	MTZJ5.6C
VD561	Diode	W05Z6.2C
VD561	Diode	MTZJ6.2C
VD404	Diode	W05Z7.5C
VD404	Diode	MTZJ7.5C
VD519	Diode	W05Z7.5C
VD519	Diode	MTZJ7.5C
VD587	Diode	W05Z10B
VD587	Diode	MTZJ10B
VD586	Diode	W05Z16B
VD586	Diode	MTZJ16B
VD302	Diode	1Z75
VD186	Diode	1N4148
VD186	Diode	2CK75D
VD188	Diode	1N4148
VD188	Diode	2CK75D
VD261	Diode	1N4148
VD261	Diode	2CK75D
VD262	Diode	1N4148
VD262	Diode	2CK75D
VD263	Diode	1N4148
VD263	Diode	2CK75D
VD403	Diode	1N4148
VD403	Diode	2CK75D
VD405	Diode	1N4148

PARTS LIST (continued)

Position	Parts	Type
VD405	Diode	2CK75D
VD582	Diode	1N4148
VD582	Diode	2CK75D
VD583	Diode	1N4148
VD583	Diode	2CK75D
VD584	Diode	1N4148
VD584	Diode	2CK75D
VD514	Diode	1N4148
VD514	Diode	2CK75D
VD516	Diode	1N4148
VD516	Diode	2CK75D
VD518	Diode	1N4148
VD518	Diode	2CK75D
VD441	Diode	RM11C
VD551	Diode	RG2
VD551	Diode	2CZ44-06E
VD301	Diode	ZFM01Z
VD183	Diode	2CZ1834
VD553	Diode	2CZ1834
VD554	Diode	2CZ1834
VD557	Diode	2CZ1834
VD517	Diode	2CZES1
VD501	Diode	RL205
VD502	Diode	RL205
VD503	Diode	RL205
VD504	Diode	RL205
VD555A	Diode	2CZEU1C
VD555A	Diode	EU1C
VD791	Diode	FG5RD
VD515	Photo coupler	LTV-816
V581	Triode	3DA2688
V581	Triode	3DG2688-L
V581	Triode	2SC2688-L
V511	Triode	3CG1015-Y
V511	Triode	2SA1015-Y
V511	Triode	2PA1015-Y
V702	Triode	3CG1015-Y
V702	Triode	2SA1015-Y
V702	Triode	2PA1015-Y
V801	Triode	3CG1015-Y
V801	Triode	2SA1015-Y
V801	Triode	2PA1015-Y
V183	Triode	3DG1815-Y

SERVICE MANUAL

PARTS LIST (continued)

Position	Parts	Type
V183	Triode	2SC1815-Y
V183	Triode	2PC1815-Y
V185	Triode	3DG1815-Y
V185	Triode	2SC1815-Y
V185	Triode	2PC1815-Y
V553	Triode	3DG1815-Y
V553	Triode	2SC1815 Y
V553	Triode	2PC1815-Y
V585	Triode	3DG1815-Y
V585	Triode	2SC1815-Y
V585	Triode	2PC1815-Y
V586	Triode	3DG1815-Y
V586	Triode	2SC1815-Y
V586	Triode	2PC1815-Y
V703	Triode	3DG1815-Y
V703	Triode	2SC1815-Y
V703	Triode	2PC1815-Y
V704	Triode	3DG1815-Y
V704	Triode	2SC1815-Y
V704	Triode	2PC1815-Y
V802	Triode	3DG1815-Y
V802	Triode	2SC1815-Y
V802	Triode	2PC1815-Y
V803	Triode	3DG1815-Y
V803	Triode	2SC1815-Y
V803	Triode	2PC1815-Y
V804	Triode	3DG1815-Y
V804	Triode	2SC1815-Y
V804	Triode	2PC1815-Y
V231	Triode	3DG1815-Y
V231	Triode	2SC1815-Y
V231	Triode	2PC1815-Y
V101	Triode	KSC388C-Y
V101	Triode	2SC388ATM
V582	Triode	2SD882
V583	Triode	3DD880
V431	Triode	3DG2383-O
V431	Triode	3DG2383-Y
V431	Triode	2SC2383-O
V431	Triode	2SC2383-Y
V431	Triode	KSC2383-O
V431	Triode	KSC2383-Y
V512	Triode	2SC3807

SERVICE MANUAL

PARTS LIST (continued)

Position	Parts	Type
V512	Triode	2SC3807A
D703	IC	HS0038/A/A2
D703	IC	SFH506-38
D703	IC	HRM3800
N101	IC	LA76814K
D701	IC	CHT0407-5P96
D702	IC	AT24C08
N141	IC	μ PC574J
N141	IC	CW574CS
N141	IC	KA33V
S501	Power switch	KDC-A04MU151
F501	Delay fuse	UCT 51S-4A-125VAC
G201	Crystal oscillator	JA18B-3.579545MHz
G701	Crystal oscillator	JA18D-32.768KHz
Z101	Surface acoustic wave filter	M1958M
X801	AV terminals	AV-2-4PC
U101	Electronic tuner	TDQ-6F2M
V432	Triode	2SD1651
V432	Triode	3DD1651
V513	Triode	2SC4458S-M
N301	IC	LA7840
N181	IC	LA4225
N503	IC	L7805CV
N503	IC	AN7805
J024	Jumper	5mm
J230	Jumper	5mm
J047	Jumper	5mm
J067	Jumper	5mm
J071	Jumper	5mm
J085	Jumper	5mm
J127	Jumper	5mm
J801	Jumper	5mm
R219A	Jumper	5mm
L511	Jumper	5mm
J120	Jumper	5mm
J075	Jumper	5mm
J080	Jumper	5mm
C266	Jumper	5mm
JM02	Jumper	5mm
J001	Jumper	7.5mm
J002	Jumper	7.5mm
J003	Jumper	7.5mm
J004	Jumper	7.5mm

PARTS LIST (continued)

Position	Parts	Type
J020	Jumper	7.5mm
J021	Jumper	7.5mm
J025	Jumper	7.5mm
J031	Jumper	7.5mm
J040	Jumper	7.5mm
J048	Jumper	7.5mm
J055	Jumper	7.5mm
J062	Jumper	7.5mm
J066	Jumper	7.5mm
J072	Jumper	7.5mm
J074	Jumper	7.5mm
J082	Jumper	7.5mm
J090	Jumper	7.5mm
J100	Jumper	7.5mm
J102	Jumper	7.5mm
J103	Jumper	7.5mm
J105	Jumper	7.5mm
J107	Jumper	7.5mm
J111	Jumper	7.5mm
J129	Jumper	7.5mm
J130	Jumper	7.5mm
J131	Jumper	7.5mm
J158	Jumper	7.5mm
J163	Jumper	7.5mm
J168	Jumper	7.5mm
J169	Jumper	7.5mm
J180	Jumper	7.5mm
J181	Jumper	7.5mm
J182	Jumper	7.5mm
J202	Jumper	7.5mm
J210	Jumper	7.5mm
J237	Jumper	7.5mm
J240	Jumper	7.5mm
J243	Jumper	7.5mm
J354	Jumper	7.5mm
J359	Jumper	7.5mm
J410	Jumper	7.5mm
J500	Jumper	7.5mm
J507	Jumper	7.5mm
J108	Jumper	7.5mm
J912	Jumper	7.5mm
VD587A	Jumper	7.5mm
J802	Jumper	7.5mm

PARTS LIST (continued)

Position	Parts	Type
R104	Jumper	7.5mm
R777	Jumper	7.5mm
R811	Jumper	7.5mm
VD209	Jumper	7.5mm
VD588	Jumper	7.5mm
J049	Jumper	7.5mm
J128	Jumper	7.5mm
R289	Jumper	7.5mm
R146	Jumper	7.5mm
R147	Jumper	7.5mm
R148	Jumper	7.5mm
R149	Jumper	7.5mm
JM06	Jumper	7.5mm
J207	Jumper	7.5mm
J411	Jumper	7.5mm
R241	Jumper	7.5mm
J008	Jumper	10mm
J028	Jumper	10mm
J029	Jumper	10mm
J035	Jumper	10mm
J059	Jumper	10mm
J076	Jumper	10mm
J078	Jumper	10mm
J086	Jumper	10mm
J104	Jumper	10mm
J109	Jumper	10mm
J123	Jumper	10mm
J125	Jumper	10mm
J137	Jumper	10mm
J139	Jumper	10mm
J140	Jumper	10mm
J143	Jumper	10mm
J151	Jumper	10mm
J167	Jumper	10mm
J191	Jumper	10mm
J193	Jumper	10mm
J198	Jumper	10mm
J199	Jumper	10mm
J203	Jumper	10mm
J209	Jumper	10mm
J241	Jumper	10mm
J341	Jumper	10mm
J347	Jumper	10mm

PARTS LIST (continued)

Position	Parts	Type
J349	Jumper	10mm
J355	Jumper	10mm
J357	Jumper	10mm
J555	Jumper	10mm
J042	Jumper	12.5mm
J056	Jumper	12.5mm
J058	Jumper	12.5mm
J073	Jumper	12.5mm
J079	Jumper	12.5mm
J126	Jumper	12.5mm
J142	Jumper	12.5mm
J144	Jumper	12.5mm
J145	Jumper	12.5mm
J166	Jumper	12.5mm
J170	Jumper	12.5mm
J177	Jumper	12.5mm
J178	Jumper	12.5mm
J184	Jumper	12.5mm
J236	Jumper	12.5mm
J244	Jumper	12.5mm
J352	Jumper	12.5mm
J358	Jumper	12.5mm
J404	Jumper	12.5mm
J061	Jumper	12.5mm
J022	Jumper	15mm
J038	Jumper	15mm
J054	Jumper	15mm
J060	Jumper	15mm
J077	Jumper	15mm
J124	Jumper	15mm
J136	Jumper	15mm
J150	Jumper	15mm
J171	Jumper	15mm
J173	Jumper	15mm
J190	Jumper	15mm
J205	Jumper	15mm
J231	Jumper	15mm
J242	Jumper	15mm
J350	Jumper	15mm
J353	Jumper	15mm
J356	Jumper	15mm
J400	Jumper	15mm
J678	Jumper	15mm

PARTS LIST (continued)

Position	Parts	Type
R422	Jumper	15mm
J032	Jumper	17.5mm
J044	Jumper	17.5mm
J050	Jumper	17.5mm
J051	Jumper	17.5mm
J070	Jumper	17.5mm
J121	Jumper	17.5mm
J133	Jumper	17.5mm
J138	Jumper	17.5mm
J160	Jumper	17.5mm
J161	Jumper	17.5mm
J201	Jumper	17.5mm
J204	Jumper	17.5mm
J239	Jumper	17.5mm
J052	Jumper	17.5mm
J188	Jumper	17.5mm
J005	Jumper	20mm
J037	Jumper	20mm
J141	Jumper	20mm
J162	Jumper	20mm
J250	Jumper	20mm
J556	Jumper	20mm
RF563	Jumper	20mm
J533	Jumper	20mm
		Parts on CRT RGB PCB
R902	Carbon film resistor	RT14-0.25W-15 Ω J
R913	Carbon film resistor	RT14-0.25W-56 Ω J
R903	Carbon film resistor	RT14-0.25W-470 Ω J
R905	Carbon film resistor	RT14-0.25W-470 Ω J
R907	Carbon film resistor	RT14-0.25W-470 Ω J
R909	Carbon film resistor	RT14-0.25W-680 Ω J
RW01	Carbon film resistor	RT14-0.25W-680 Ω J
RW02	Carbon film resistor	RT14-0.25W-680 Ω J
RW03	Carbon film resistor	RT14-0.25W-680 Ω J
R904	Carbon film resistor	RT14-0.25W-750 Ω J
R906	Carbon film resistor	RT14-0.25W-750 Ω J
R908	Carbon film resistor	RT14-0.25W-750 Ω J
R911	Carbon film resistor	RT14-0.25W-1K Ω J
R912	Carbon film resistor	RT14-0.25W-1K Ω J
R910	Carbon film resistor	RT14-0.25W-2.7K Ω J
R917	Carbon film resistor	RT15-0.5W-1.2K Ω J
R918	Carbon film resistor	RT15-0.5W-1.2K Ω J
R919	Carbon film resistor	RT15-0.5W-1.2K Ω J

SERVICE MANUAL

PARTS LIST (continued)

Position	Parts	Type
R914	Metal oxide film resistor	RY21-2W-18K Ω J
R915	Metal oxide film resistor	RY21-2W-18K Ω J
R916	Metal oxide film resistor	RY21-2W-18K Ω J
C901	Ceramic capacitor	CT1-63V-06a-2B4-330PFK
C902	Ceramic capacitor	CT1-63V-06a-2B4-330PFK
C903	Ceramic capacitor	CT1-63V-06a-2B4-330PFK
C910	Ceramic capacitor	CT81 1KV 10c-2B4-1000PFM
C909	Ceramic capacitor	CT81-400VAC-10C-2E4-1000PFM-Y1
C909	Ceramic capacitor	CD85-E2GA102MYHS
C909	Ceramic capacitor	CT71-400VAC-10d-2E4-1000PFM-Y1
C906	Aluminum electrolytic capacitor	CD110X-16V-470 μ FM
C907	Aluminum electrolytic capacitor	CD110-50V-0.47 μ FM
C904	Aluminum electrolytic capacitor	CD110-50V-10 μ FM
C905	Aluminum electrolytic capacitor	CD110-50V-22 μ FM
L901	Fixed inductor	LGB0606-10 μ HK
D901	Diode	1N4148
D901	Diode	2CK75D
D902	Diode	1N4148
D902	Diode	2CK75D
D903	Diode	1N4148
D903	Diode	2CK75D
D904	Diode	1N4148
D904	Diode	2CK75D
D905	Diode	1N4148
D905	Diode	2CK75D
D906	Diode	1N4148
D906	Diode	2CK75D
V905	Triode	3CG1015-Y
V905	Triode	2SA1015-Y
V904	Triode	3DG1815-Y
V904	Triode	2SC1815-Y
V901	Triode	2SC2621ERA
V901	Triode	3DG2688-L
V902	Triode	2SC2621ERA
V902	Triode	3DG2688-L
V903	Triode	2SC2621ERA
V903	Triode	3DG2688-L
GZ01	GZS CRT socket	GZS10-2-DD
W909	Jumper	5mm
W901	Jumper	7.5mm
W902	Jumper	7.5mm
W905	Jumper	12.5mm
R920	Jumper	20mm

SERVICE MANUAL

PARTS LIST (continued)

Position	Parts	Type
W904	Jumper	20mm
		Parts on AV PCB
XS803	AV terminals	AV-1-3PF
		Other Parts
VE901	14" CRT	37SX110Y22-DC05
XS501	Power cord	RVVZ-2U2M-C2143-TJC1-3Y
XS502	Degaussing coil	XC-14E1(JU4.759.003)
B301	Electric speaker	YDT57-A1-5W-16Ω
B302	Electric speaker	YDT57-A1-5W-16Ω
		If using BMCC CRT, remove the following parts from the parts list when using Rainbow CRT.
		Remove the following parts from the main PCB.
RF481	Fuse resistor	RF10-1W-1.8ΩJ
C436	Ceramic capacitor	CT81-2KV-10c-2B4-470PFK
C435	Polypropylene capacitor	CBB81-1.6KV-7200PFJ
L441	Horizontal linearity inductor	HXT39
T432	FBT	BSC60T(JUB4.799.012)
		Remove the following parts from the CRT RGB PCB.
GZ01	GZS CRT socket	GZS10-2-DD
R920	Jumper	20mm
W904	Jumper	20mm
		Remove other parts.
VE901	14" CRT	37SX110Y22-DC05
		If using BMCC CRT, add the following parts to the parts list when using Rainbow CRT.
		Add the following parts to the main PCB.
RF481	Fuse resistor	RF10-1W-3.9ΩJ
C435	Polypropylene capacitor	CBB81-1.6KV-6200PFJ
L441	Horizontal linearity inductor	HXT65
T432	FBT	BSC60T2(JUB4.799.012-1)
		Add the following parts to the CRT RGB PCB.
GZ01	GZS CRT socket	GZS8-6-4-2
W980	Jumper	10mm
R920	Jumper	17.5mm
W904	Jumper	17.5mm
		Add other parts.
VE901	14" CRT	A34JQQ90X94

R AT1302 COLOR TV RECEIVER

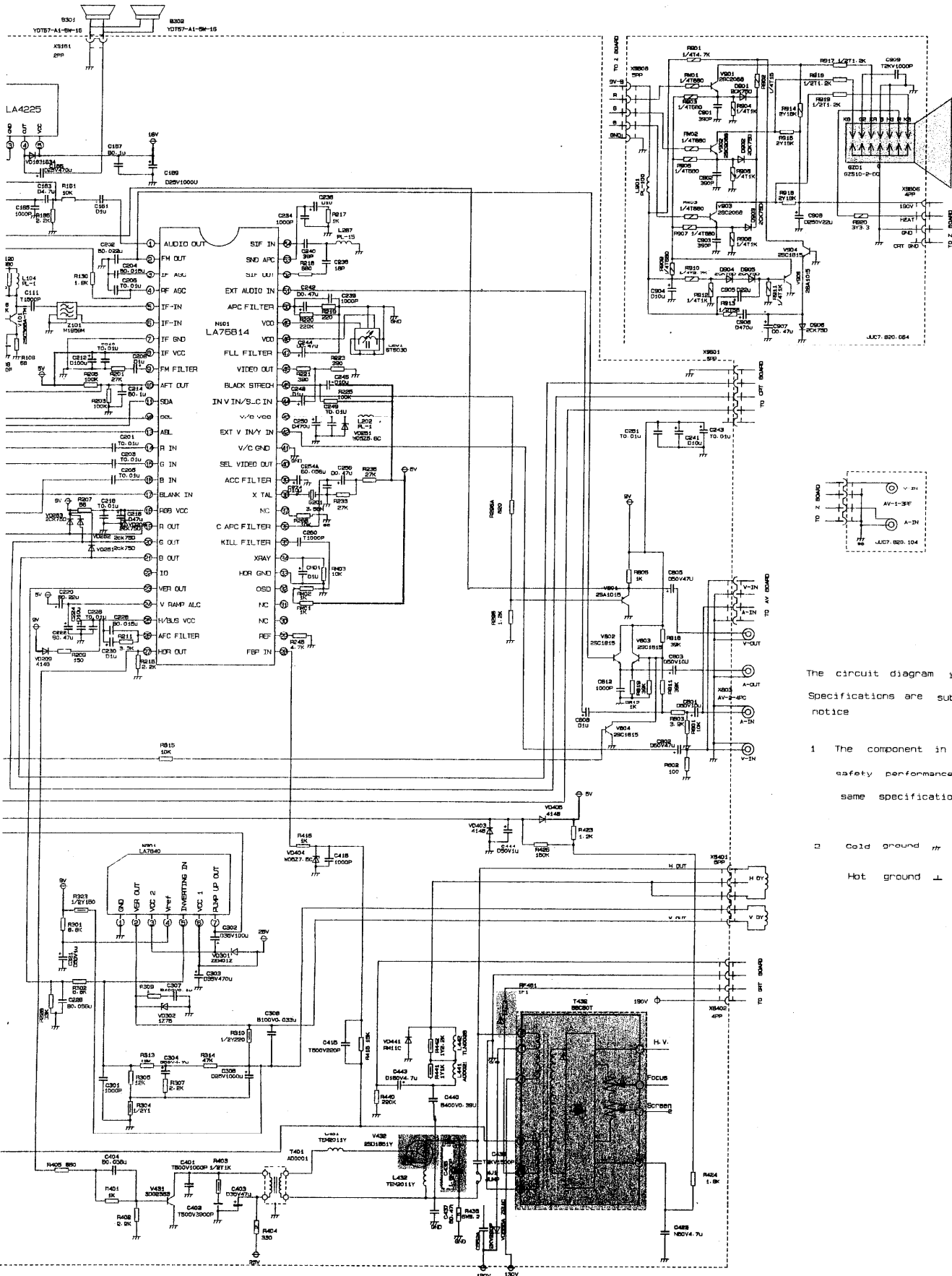

The circuit diagram is only for reference. Specifications are subject to change without notice.

- 1 The component in shadows has special safety performance. Replace it with the same specifications as the original's.
- Cold ground
- ⊥ Hot ground

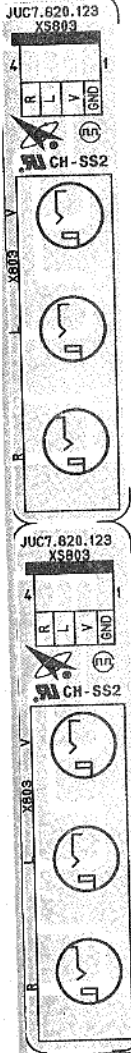

A B C D E F T 1 2 3 4

JUC7.820.123 03-23-2002

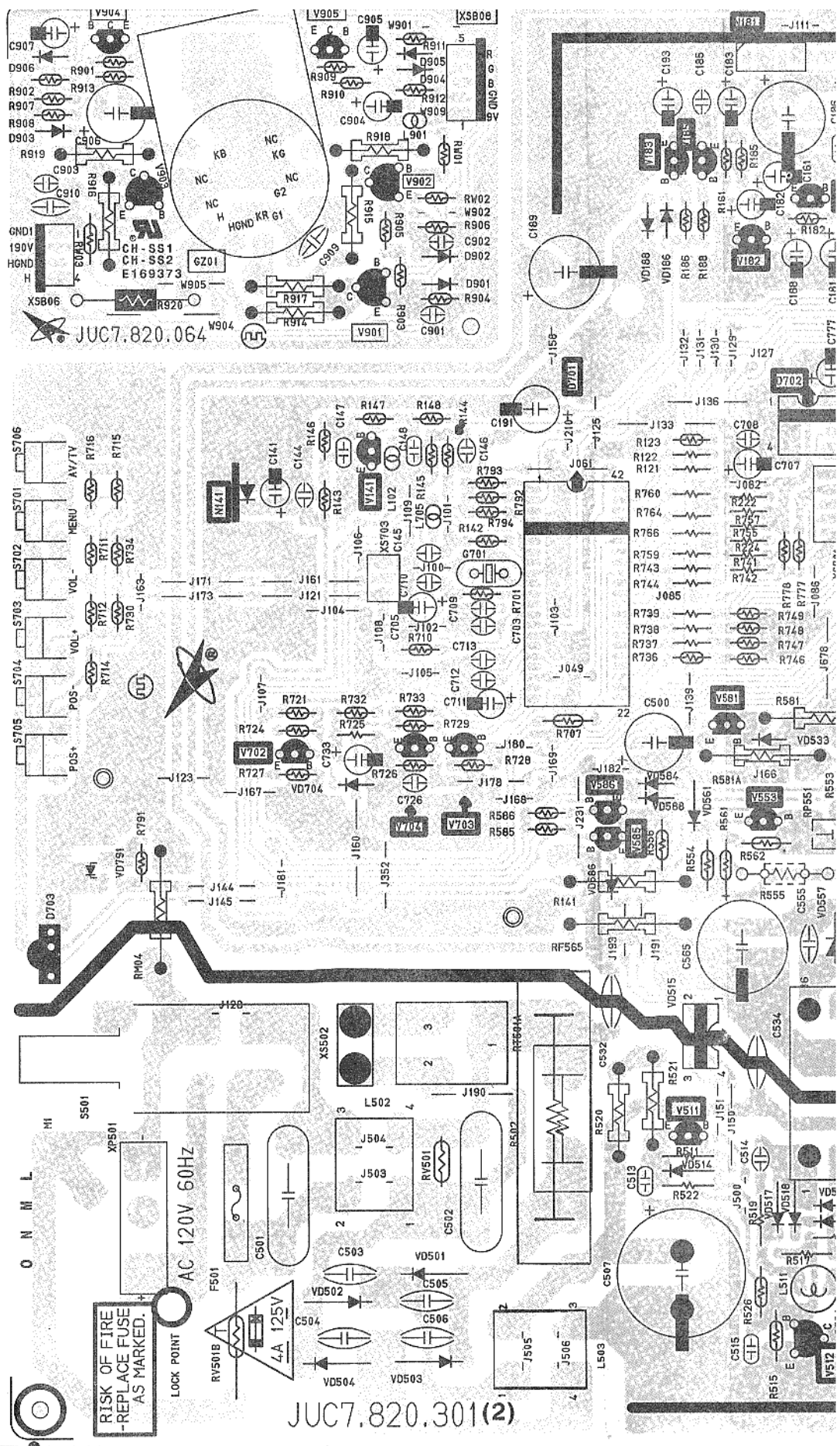

JUC7.820.301(2)

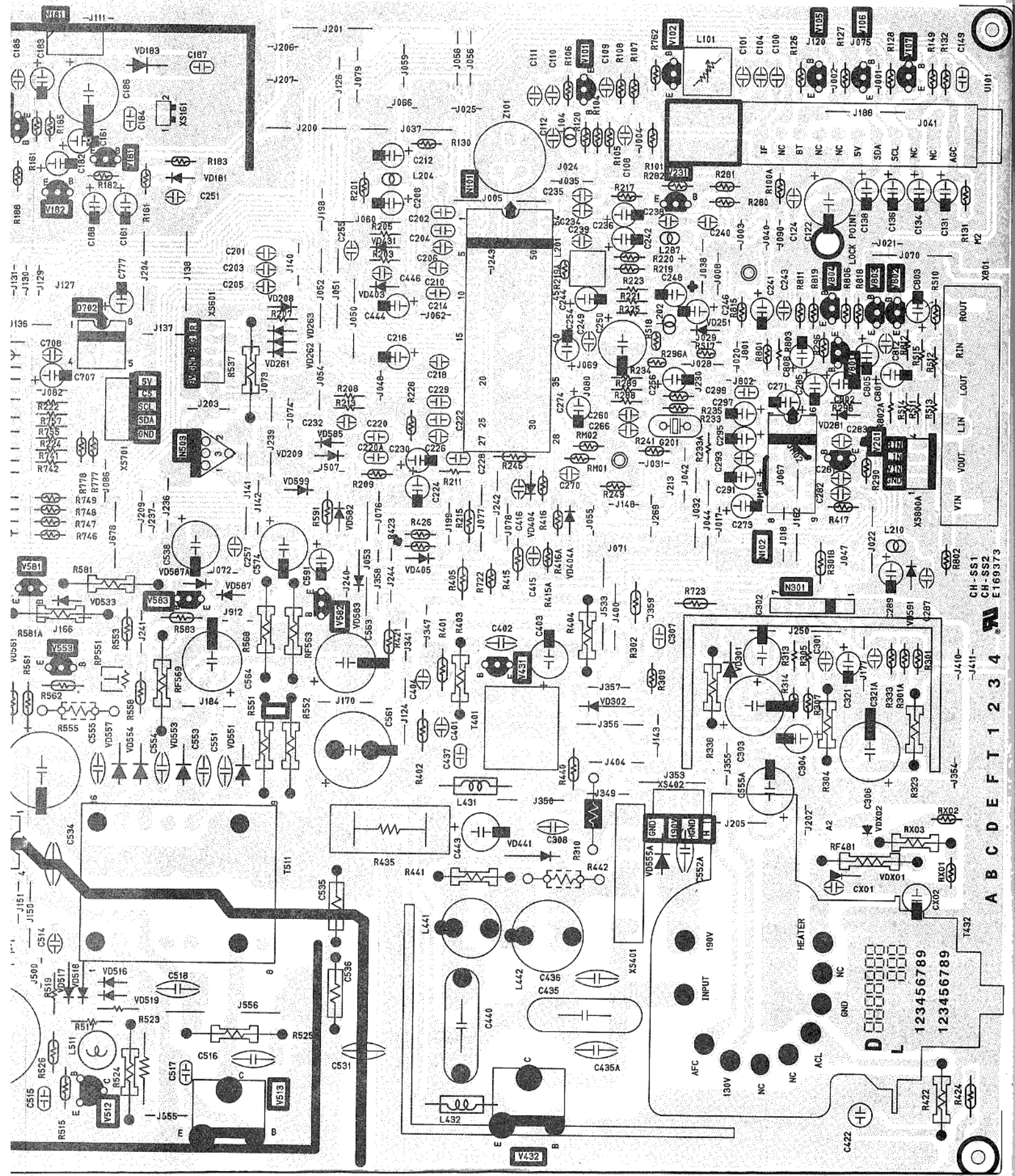

CH-SS1
 CH-SS2
 E169373
 A B C D E F T 1 2 3 4

123456789
 123456789

APPENDIX 3 FINAL WIRING DIAGRAM FOR AT1302

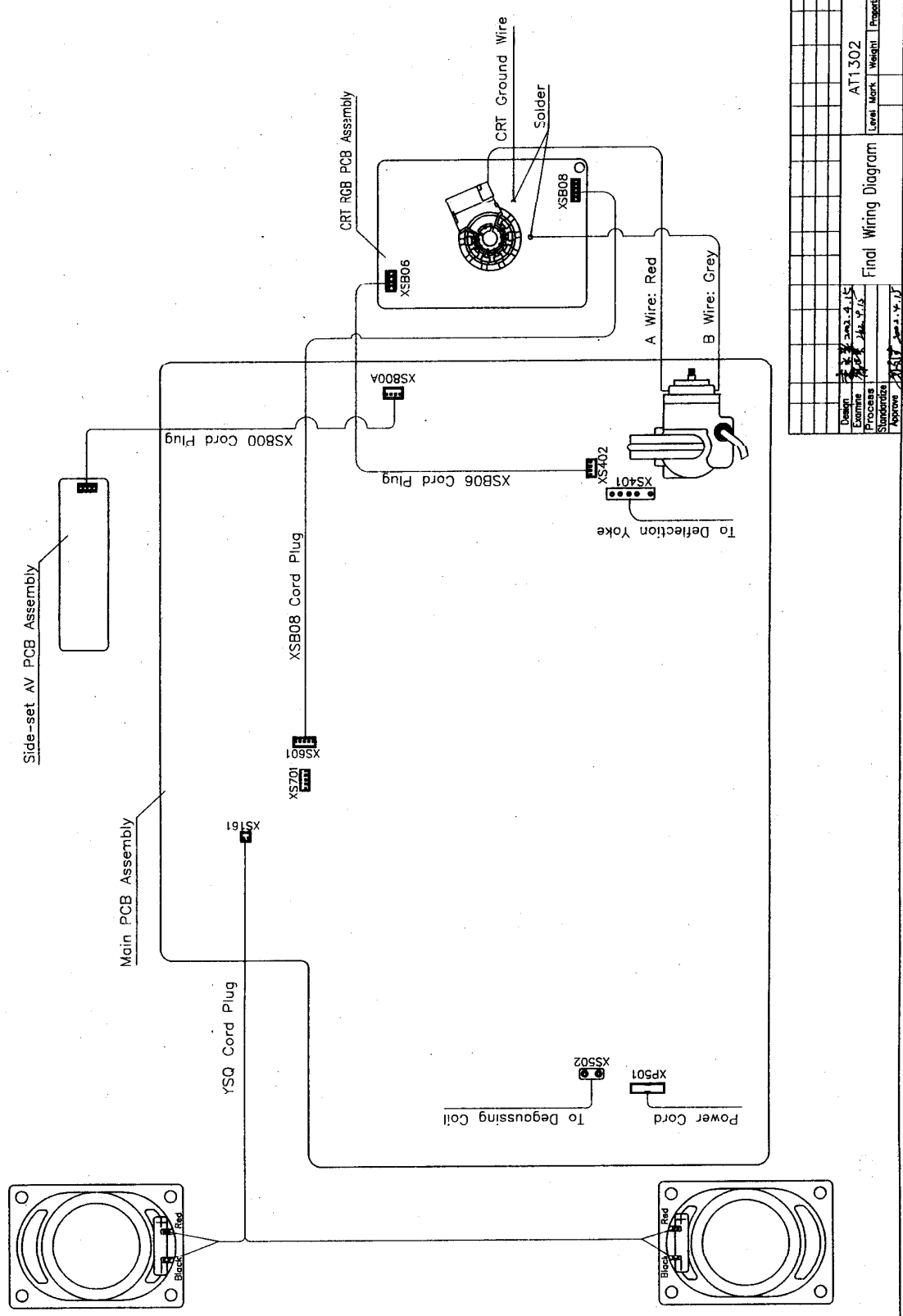

Drawn By	Rev.
Checked By	Rev.
Date	Sign.

Final Wiring Diagram		
Design	AT1302	Level
Examine		Mark
Process		Weight
Substrate		Preparation
Approve		

Width: A2

Tracing

Format (1)

+
-
+

